



**HELIX**  
HYDRO



**FILTAWORX**  
*Self Cleaning Filters*



**AUTOMATIC FILTER  
OPERATIONS MANUAL  
FW50 to FW100**



# TABLE OF CONTENTS

<b>Safety Warnings</b> .....	<b>1</b>
<b>Introduction and Installation</b> .....	<b>2</b>
Filter Components.....	2
Operation.....	2
Filter Installation.....	6
Filter Commissioning.....	7
<b>Operating Instructions</b> .....	<b>9</b>
General Operations.....	9
Maintenance Schedule.....	10
Opening the filter for inspection.....	11
Trouble Shooting.....	13
<b>Spare Parts</b> .....	<b>14</b>
Common Spare parts for all Filter Sizes.....	14
Controllers Configuration.....	15
Cover Lid.....	21
FW50-FW100 Filter BOM.....	22 - 23
Screen Removal Instructions.....	27
<b>Annexes</b> .....	<b>28</b>

## LIST OF ANNEXES

ANNEX A Filter Data Sheets.....	28
ANNEX B Filter Dimensional Data.....	30
Warranty.....	32

## SAFETY WARNINGS



In operation the filters will contain pressurised water, this must be released prior to any operation accessing the filter internals or control tubes.



In operation the filter is connected to pressure piping, the filter must be isolated from the piping, both upstream and downstream, prior to operation accessing the filter internals or control tubes.



Residual water will remain in the filter when opened, ensure this is contained so it does not flow to any electrical connections or cabling.



Even with the pressure released from the filter, the control lines may still hold some pressure, on release ensure any spray is not directed to electrical equipment or personnel.



The water contained in the filter may have been stored for some time and is stagnant or from a contaminated source.

In all operations wear protective gloves and eye protection. Avoid touching bare skin after exposure to the water.



When disassembling the filter, many components are heavy and difficult to lift. Ensure you have assistance or applicable lifting equipment available.

In all operations wear protective gloves, foot and eye protection.

**Failure to comply may result in severe injury or death to personnel and damage to equipment.**

### List of Abbreviations

DP	Differential Pressure
B.o.M	Bill of Materials
A	Assembly
P	Part / Component

# INTRODUCTION AND INSTALLATION

## Introduction

1. Congratulations on purchasing a Filtaworx® automatic self-cleaning filter. Filtaworx® filters are manufactured from the highest grade materials and supported by a comprehensive quality program to ensure a long trouble free operation.
2. Please read the following manual carefully and follow all instruction to obtain the best performance from your filter.

## Filter Components

3. Please see Figure 1 below indicating the main filter components

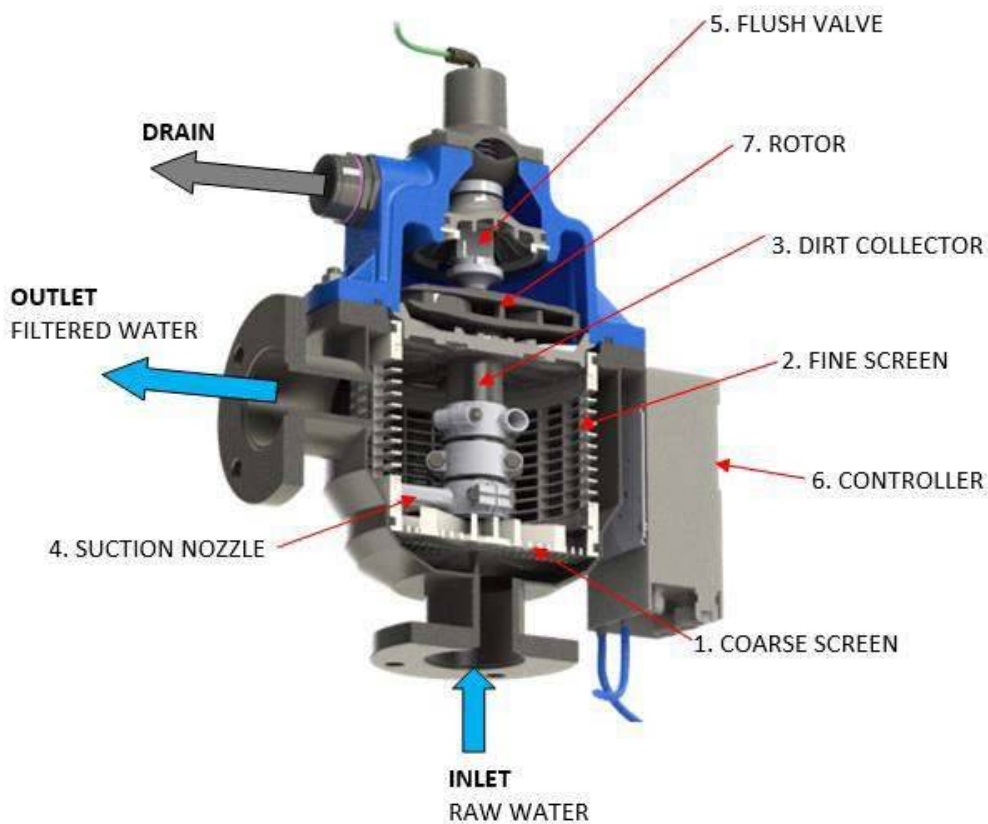
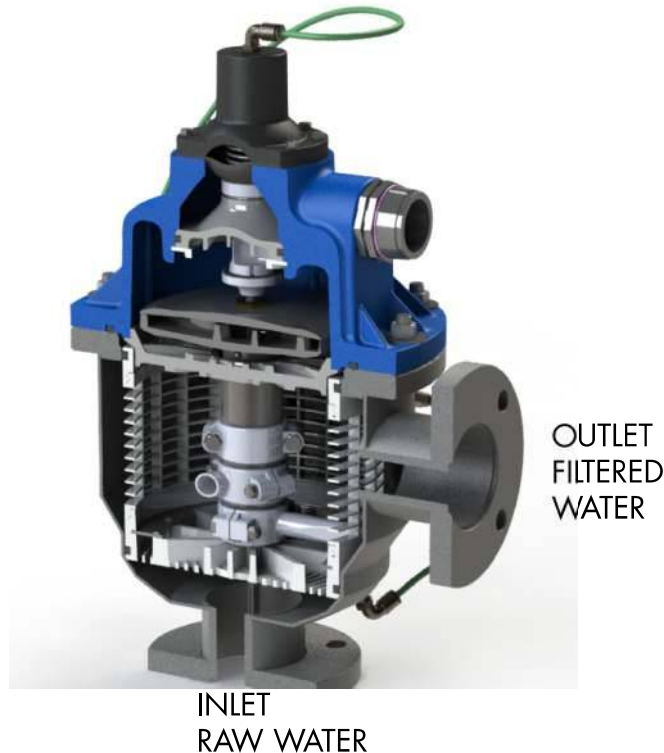

Figure 1 Filter Components

## Operation

4. Filtaworx® automatic filters have a self-cleaning function. When activated a filter flush will occur, the internal nozzles travel over the screen internal, vacuuming the filter fine screen, the contaminants are ejected from the drainpipe. Typically, this operation is triggered by a differential pressure (DP) across the filter of 50 kPa (7 psi). Each operation of the flush should take between 5-7 seconds. While flushing, the filter continues to operate normally with clean water exiting the outlet.

5. The flush can be triggered three ways depending on the control supplied:
  - a. Hydraulic control - a diaphragm in the rinse controller will send the system into flush at 50 kPa (7 psi). This is factory set and cannot be adjusted.
  - b. Electric Control - a control module will monitor the DP, activating a solenoid to send the system into flush, factory set to 50 kPa (7 psi), this can be adjusted, additionally the current DP is displayed. This controller will also allow for flush activation on a settable time interval regardless of the DP.
  - c. PLC control - a normally open pressure switch will close at set DP, factory set at 50 kPa (7 psi), signalling the PLC (not supplied) a flush is required. When downstream operations allow, the PLC will send a signal to activate a solenoid to send the system into flush.
  
6. Flush operation:
  - a. Filter in steady state normal operation with piston in standard position with no flush operation, the drain valve is closed. Water flows from inlet to outlet only. See Figure 2 below.



**Figure 2 Flush Valve in steady state position, drain closed**

- b. Filter enters flush, the flush valve moves away from steady state position, this opens the drain valve and flush begins. Water will now flow from inlet to both outlet and drain, thus a slight loss of pressure and flow to main outlet. See Figure 3 below.

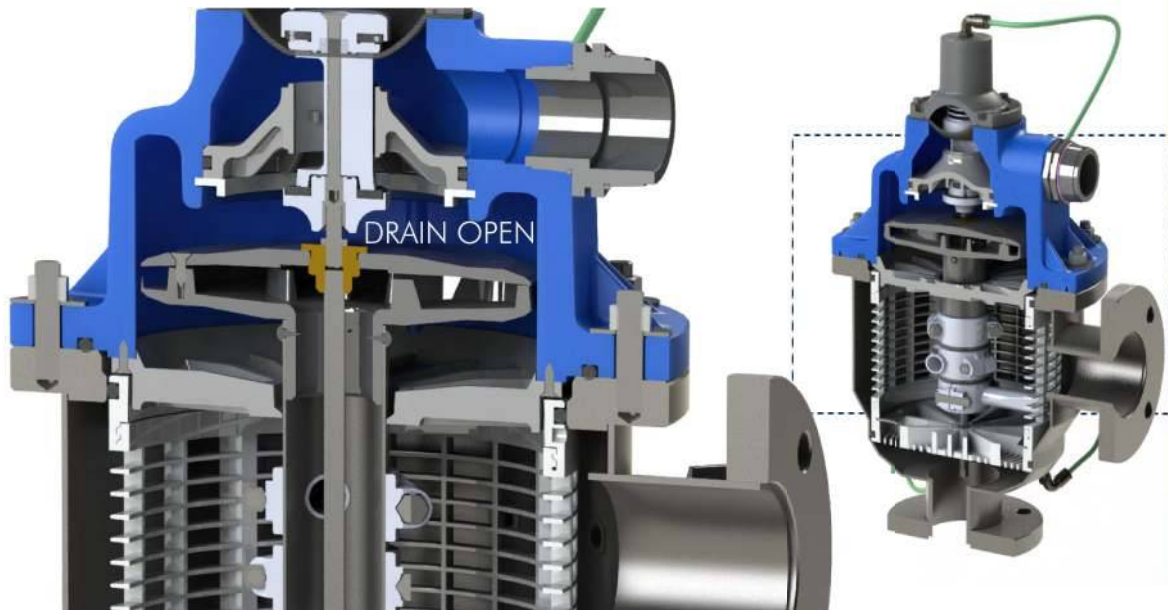

**Figure 3 Flush Valve with drain Open.**

- c. When the Flush Valve reaches the end of its stroke, the drain will close again, flush will pause, but is not complete. See Figure 4 below.

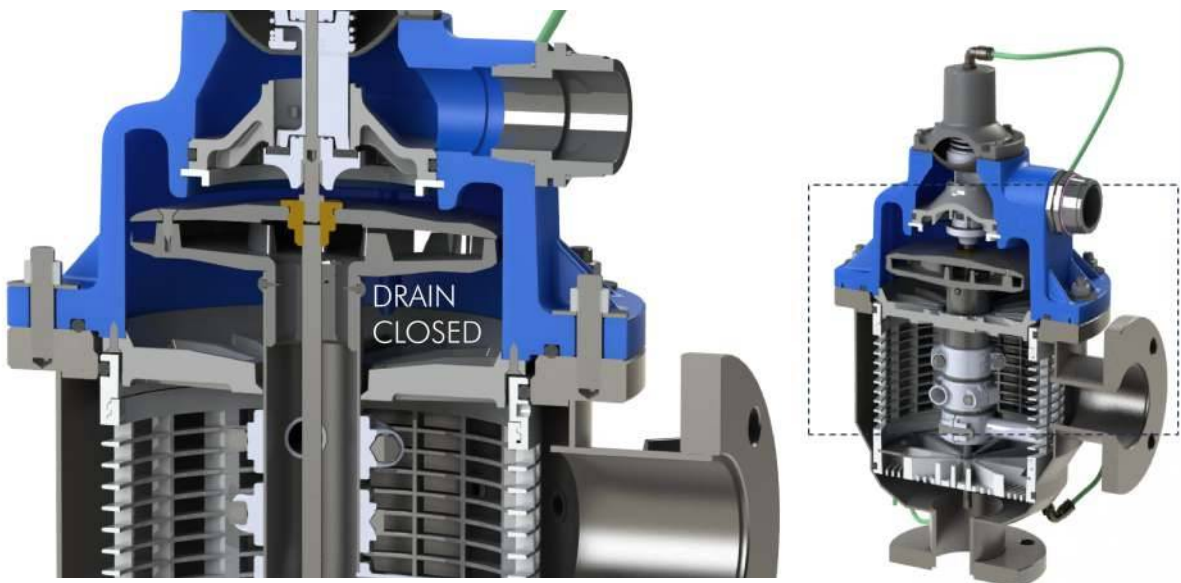

**Figure 4 Flush Valve at end of stroke, drain closed.**

- d. The flush valve will now return to steady state position, again opening the drain valve, giving the fine screen additional cleaning. Operation is now complete. See Figure 5 below.



**Figure 5 Flush Valve back in steady state position, drain Closed.**

## Filter Installation

7. Please see Figure 6 below for a typical installation, the filter can be installed in any orientation and the cover lid can be rotated to suit drain exit. Please note the critical items below:

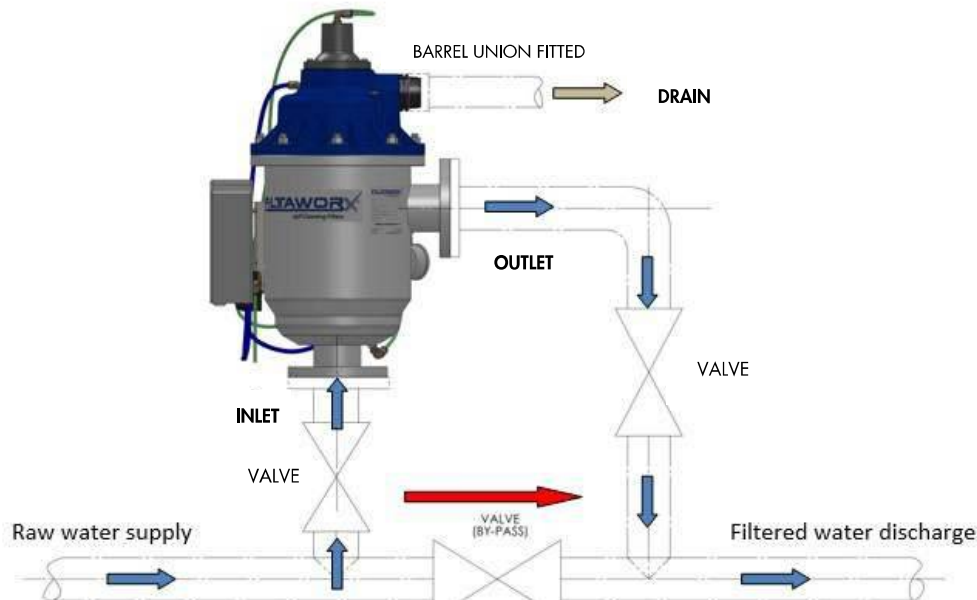
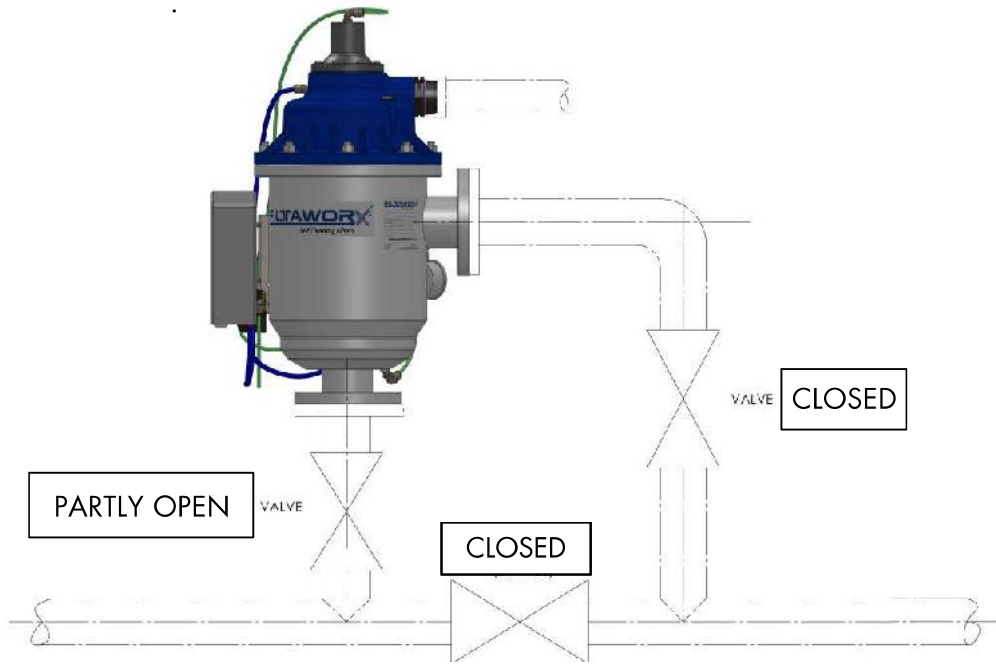

**Figure 6 Filter Installation**

- a. The filter is delivered tested and in operational condition. Only items that must be fitted prior to use other than piping are:
  - i. For Electric Control connect to mains power or fit batteries, if required for DC model.
  - ii. For PLC Control, connect PLC cables as required.
- b. Isolation valves at inlet and outlet.
- c. Barrel union fitted to drain line for easy removal of coverlid, during service.
- d. Drain pipework is a minimum DN50 (2") to prevent back pressure. If the drain is longer than 10m, use DN80 (3") pipework.
- e. Drain line is down hill only with minimum length.
- f. Ensure sufficient service space around the filter as per dimension in Annex B.
- g. During flush, water will also drain from below. This can be piped away but ensure little to no back pressure.
  - i. Rinse controller, DN25 (1") BSP piping.
  - ii. Electric and PLC control 8 mm nylon tubing.
- h. Ensure water will not flow backwards through the filter, this can damage the fine screen.
- i. A bypass line for critical installations but would strongly recommend a backup filter to protect downstream infrastructure.
- j. For PLC only: The PLC (not supplied by Filtaworx®) will be used to control the flush of the filter, it must be programmed:
  - i. A close signal from the pressure switch on the filter will indicate a flush is needed.
  - ii. As soon as possible after this signal the PLC must send a 24V (AC or DC specified by user) to the solenoid on the filter, and held on for 15 seconds.
  - iii. The PLC will ignore all signals from the pressure switch for 30 seconds after the solenoid signal has finished to allow the flush to complete and turbulence to subside.

## Filter Commissioning

8. Once the filter is installed, and pressure is available, the filter is ready to commission.
9. Fill the filter with water, close the outlet valve and part open the inlet, you will hear water entering the filter. This will take a few minutes. See Figure 7 below.
10. Note the filter may flush during this process and some water may go through the drain.



**Figure 7 Filter Fill with Water**

11. Once the filter is filled with water and pressurised, check and fix any connection leaks at flanges and drain connections.
  - a. On Hydraulic control units, make sure the 3 way tap is pointed to Auto seen Figure 8 below.
  - b. No action required for other controllers.



**Figure 8 3-Way tap in Auto position**

12. Open the inlet valve fully, keep the outlet valve closed, and do a test flush:
  - a. Hydraulic Control, turn the 3-way tap from Auto to Open, wait 1-2 seconds, return to Auto. See Figure 9 below. Note: Water will eject from the drain line.



**Figure 9 Tap turned to Open, then back to Auto for flush**

- b. Electric control, press the "M" button on the controller, may need to press twice, first to enable display.
  - c. PLC, will need to request PLC send signal to solenoid.
13. During the first flush, the system may cause some water hammer during the flush, as the air is removed. Repeat 2 or 3 more flushes remove all air and initialise the filter.
  14. Slowly open the outlet valve, to let the water flow downstream .
  15. Do another manual flush as per item 12. The system is now operational.

# OPERATING INSTRUCTIONS

## General Operations

16. Once installed the Filtaworx® Automatic Filter will work automatically and requires very little user input.
17. The filter inlet and outlet pressures can be checked with the connected pressure gauge. This can be used as per below.
  - a. To check inlet pressure (dirty water side), turn the 3-way tap to the hose connector as per Figure 10 below.



**Figure 10** Tap turned for inlet pressure

- b. To check outlet pressure, (clean water side), turn the 3-way tap to the filter as per figure 11 below.



**Figure 11** Tap turned to to outlet pressure

18. A manual flush can be initiated by following the instructions in item 12.

## Maintenance Schedule





19. Follow the maintenance and inspection schedule as per below table. The frequency indicated is for a filter in low to moderate conditions, that would normally auto flush every few hours.
20. If the filter is flushing more regularly in heavy conditions, then increase the frequency of the checks. Note water contamination will change due to environmental conditions, such as flooding or extended high temperatures.
21. Please refer to the parts breakdown for the location of the items mentioned below.



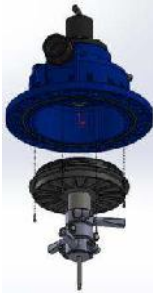

**Table 1 Maintenance Schedule**

No.	Item	Frequency	Inspection Task
1	Flushing	Once per 2 weeks	Manual flush the filter and check inlet/outlet pressure before and after flush to ensure cleaning is operating correctly.
2	Fine Screen	Once per 6 months / 12 months	Remove inspect and clean the fine screen from filter, if only small build up this can be extended to 12-month frequency.
3	Upper bearing	Once per 12 months	Inspect for wear, replace if needed.
4	Coverlid	Once per 12 months	Check that the flush valve moves smoothly up and down.
5	Seal Washer	Once per 12 months	Check for wear, replace if required.

## Opening the filter for inspection

22. Please following the instructions below for opening the filter for inspection/ maintenance.

No.	Task	Information
1	Ensure you have read all safety warning at start of manual prior to proceeding.	
2	Ensure filter is running at pressure above 200 kPa (30 psi) and perform 3 manual flushes as per para 12 to clean filter.	
3	Close both inlet and outlet isolation valves, system pump may need to be shut down.	
4	Perform another manual flush, this will release the water pressure. Check the pressure gauge as per item 17, it should read zero.	
5	If the pressure gauge does not read zero, flush again, investigate why pressure is trapped in the filter.	
6	Remove the flexible tubing from the coverlid, clearly label so it can be returned to original pipe fittings.	
7	Remove bolts holding down coverlid, and release union on drain. Lift the coverlid off the filter, note water will drain-out.	

No.	Task	Information
8	Remove the fine screen as per instruction A-15040-EV using the tool provided with the filter. Note this may take some effort if the filter has not been cleaned in some time. A lever may be required.	
9	Once separated use a pressure cleaner to clean the fine screen, but only from the inside out. Pressure cleaning from the outside will damage the screen.	
10	To remove the collector assembly, remove the 4 x Phillips head-screws that attach the Partition to the coverlid. The collector assembly will now pull out of the coverlid, exposing the bearings and flush valve assembly.	
11	The filter is now broken down into its major parts, for further disassembly please refer to the parts section for exploded views.	

## Trouble Shooting

23. Please see below instructions for trouble shooting any issues with filter operation.

Problem	Possible Cause	Solution
Hydraulic control rinse controller continually draining	Filter has access material in fine screen	Check pressure gauge for DP, if over 50 kPa (7 psi) perform a manual clean on filter
	Rinse controller has dirt build up, not operating correctly	Check pressure gauge for DP, if under 50 kPa (7 psi), contact Distributer for parts
Drain valve not closing	Insufficient Pressure	Ensure the filter has over 200 kPa (30 psi) of pressure
	Control tube blocked	Check all control tubes to piston end cover
	Seal washer damaged	Remove coverlid and check seal
	Bearing failed	Remove coverlid and check bearings
Continuous flushing	Diaphragm Damaged	Remove diaphragm cover and inspect diaphragm for wear and holes
	Filter has excess material in fine screen	Check pressure gauge for DP, if over 50 kPa (7 psi) perform a manual clean on filter controller
No flow though filter	Filter is blocked due to not self-cleaning.	Check pressure gauge for DP, if over 50 kPa (7 psi) try a manual clean a number of times. If this cleans the filter: <ul style="list-style-type: none"> <li>- Check control tubes for blockages</li> <li>- Check the DP on the Electric controller is accurate and 0.5 bar is set for the flush point</li> <li>- On electric control and PLC ensure the solenoid is operating and has no blockage</li> </ul>
		Check pressure gauge for DP, if over 50 kPa (7 psi) try a manual clean a number of times. If this does not clean the filter: <ul style="list-style-type: none"> <li>- filter is overloaded and cannot clean organic matter, do manual clean</li> <li>- Filter has an internal failure, disassemble and investigate</li> </ul>

# SPARE PARTS

## Common Spare parts for all Filter Sizes

24. Control system layout.

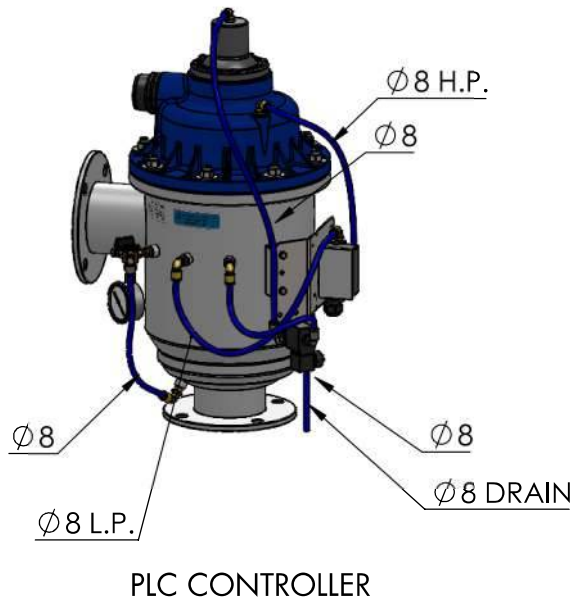
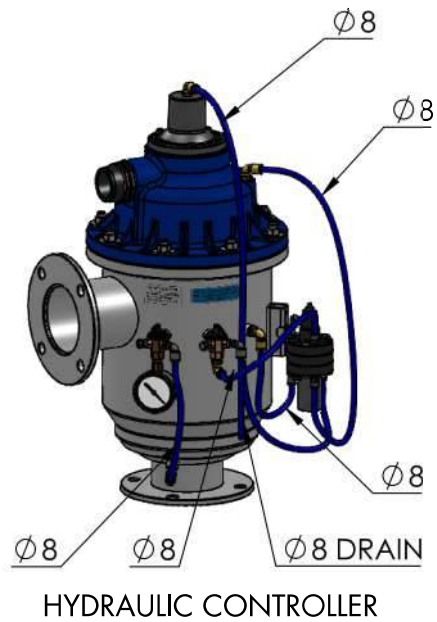
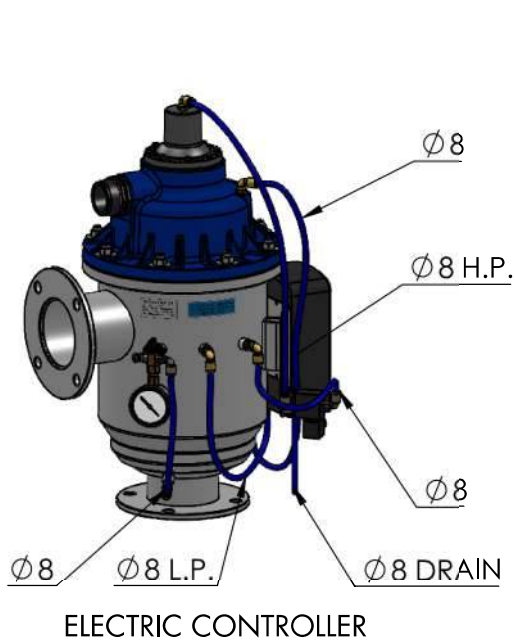

## Electric Control

ITEM NO.	PartNo	DESCRIPTION	REV	QTY.
1	P-15103	MOUNTING BRACKET	8	1
2	P-15131	Filtron 1-10	-	1
3	P-14005	8G x 3/8" L SELF TAPPING SCREW -PAN HEAD	-	4
4	P-15104	3/2-way Miniature Solenoid Valve	0	1
5	P-14730-4	1/8" BSPT - 8MM ELBOW FITTINGS	-	2
6	P-14734	1/8" BSP Female 8 mm Elbow Fitting	-	1
7	P-14009	M4x10L Set Screw - Pen Head	-	4

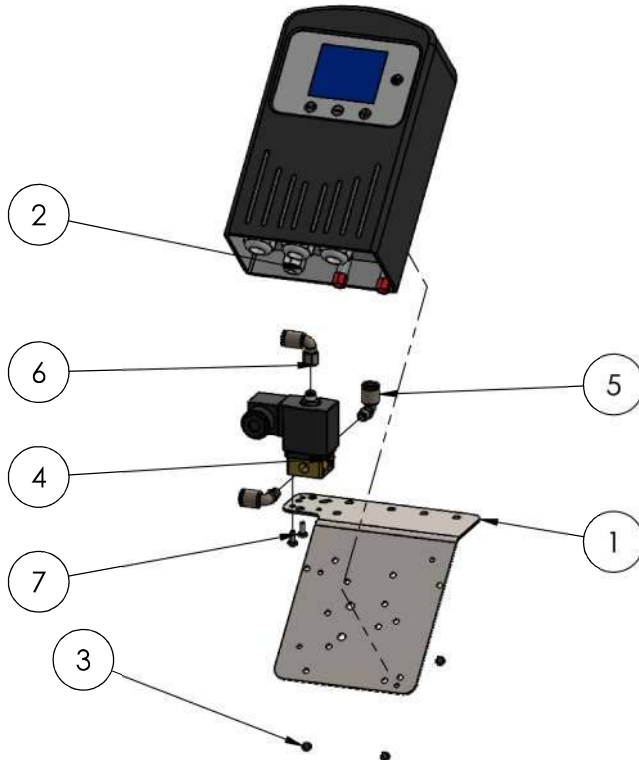

WATER SUPPLY  
TO PORT-ON COVER LID

WATER SUPPLY  
FROM PORT-1  
ON FILTER BODY

DRAIN

LOW PRESSURE  
TO PORT-5 ON FILTER BODY  
OR  
TO FLANGE BOSS OF OUTLET

PARALLEL MOUNTING  
(FW100EX ~ FW450FILTERS)

HIGH PRESSURE  
TO PORT-7 ON COVER LID

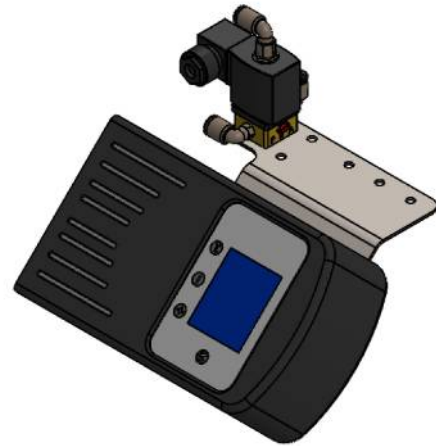

PERPENDICULAR MOUNTING  
(FW050 ~ FW100FILTERS)

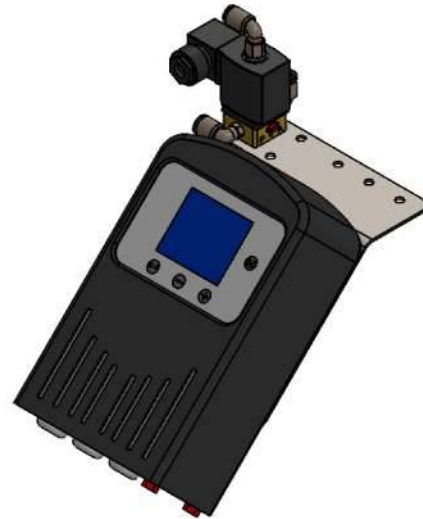

CONNECTION	
CONTROLLER	FITTING
P	1
B	3
R	DRAIN
HP	7
LP	5

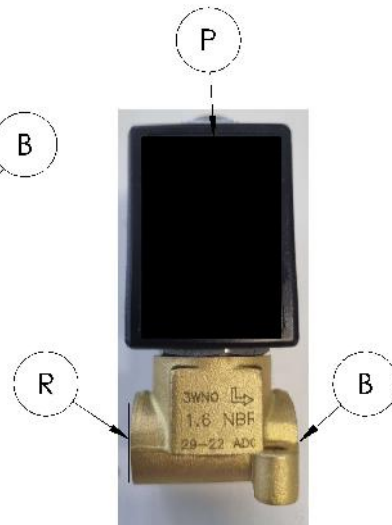
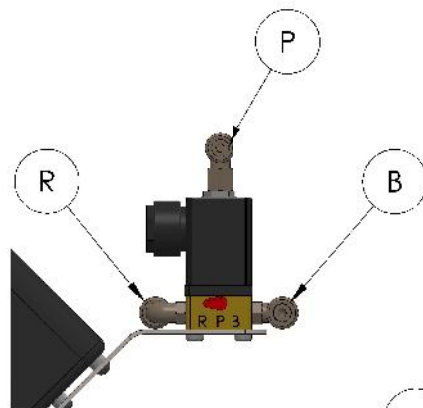
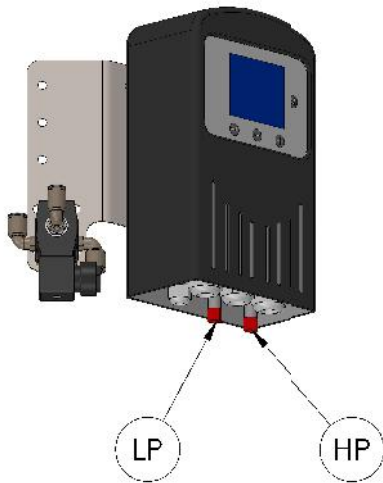
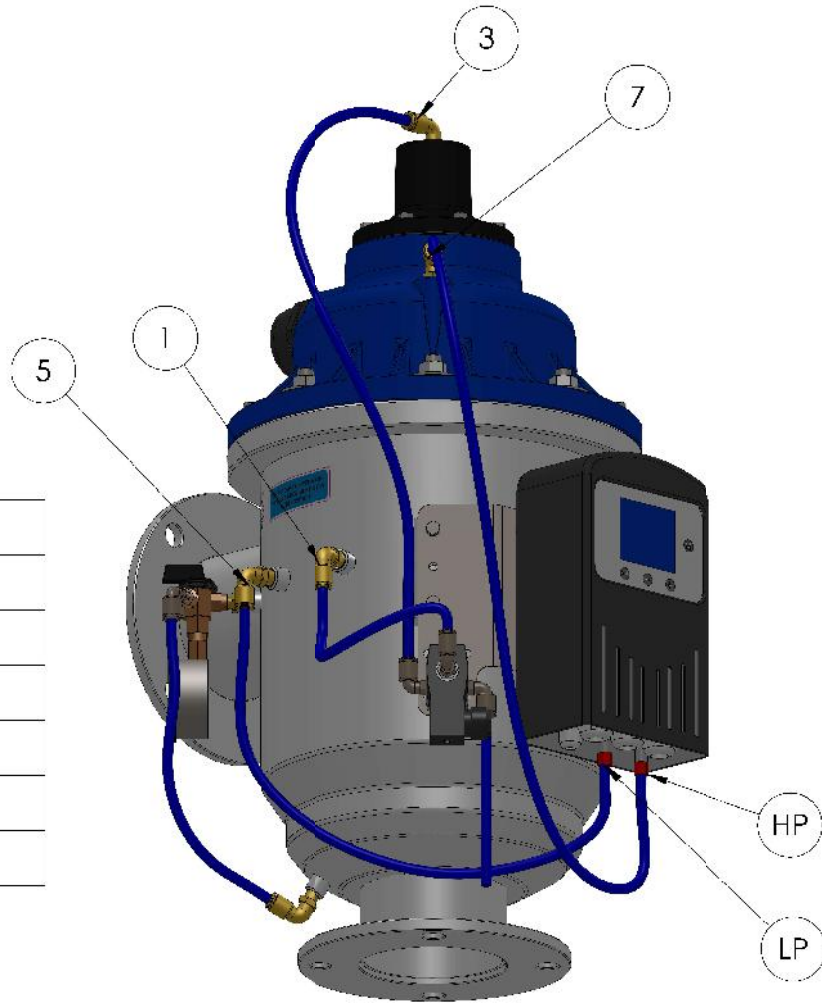

## ELECTRIC CONTROLLER CONNECTION

## Hydraulic Control

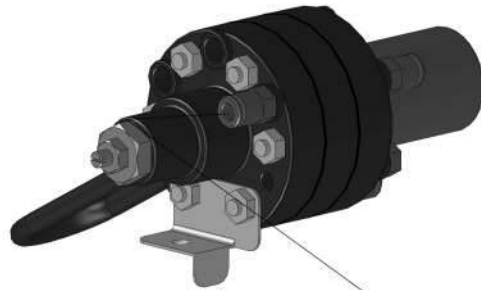

$\phi$  8 WATER SUPPLY  
FROM PORT-2 ON FILTER BODY

$\phi$  8 WATER SUPPLY  
TO PORT-5 ON COVERLID

$\phi$  8 WATER SUPPLY  
TO PORT-7 ON COVER LID



DN25 (1") BSP DRAIN

$\phi$  8 WATER SUPPLY  
FROM PORT-3 ON FILTER BODY

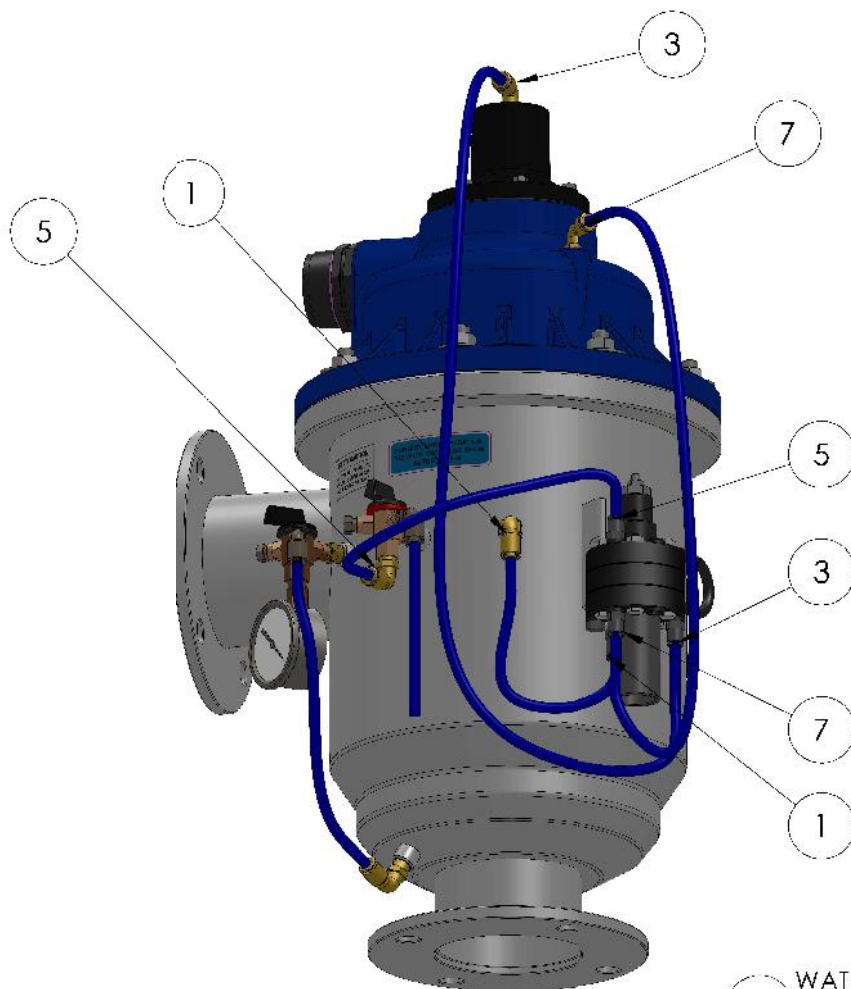

7 WATER SUPPLY FROM PORT- 7 COVER LID

5 WATER SUPPLY FROM PORT- 5 ON FILTER BODY

3 WATER SUPPLY FROM PORT- 3 COVER LID

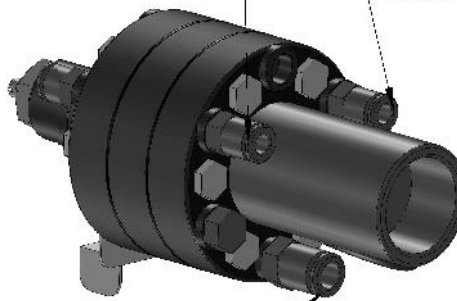
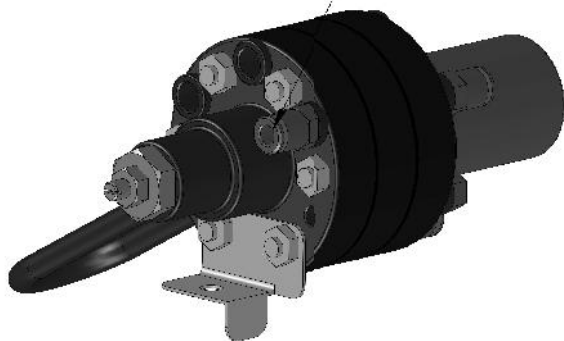

1 WATER SUPPLY FROM PORT- 1 ON FILTER BODY

## HYDRAULIC CONTROLLER CONNECTION

## PLC Control

ITEM NO.	PartNo	Description	Revision	QTY.
1	P-15103	MOUNTING BRACKET	8	1
2	P-15104	3/2-way Miniature Solenoid Valve	0	1
3	P-14730-4	1/8" BSPT - 8MM ELBOW FITTINGS	-	2
4	P-14734	1/8" BSP Female 8 mm Elbow Fitting	-	1
5	P-14009	M4x10L Set Screw - Pen Head	-	4
6	P-15139	Differential Pressure Switch	0	1
7	P-14713-4	1/4" BSPT - 8mm Elbow Fitting	0	2
8	P-14058-1	M4x16L Set Screw	0	1
9	P-14059-1	M4 Flat Washer	0	1
10	P-14060-1	M4 Hex. Nut	0	1

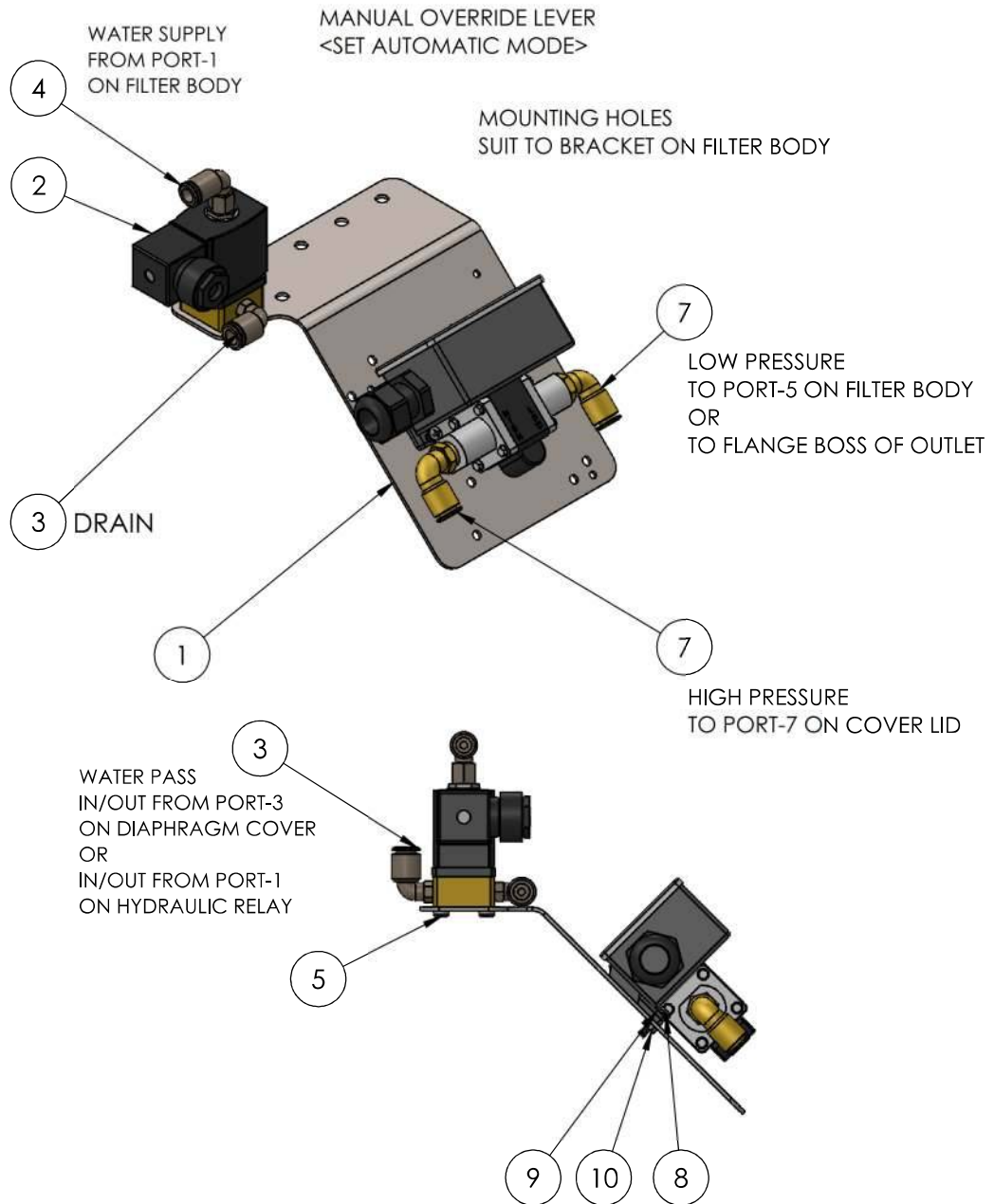

CONNECTON	
CONTROLLER	FITING
P	1
B	3
R	DRAIN
HP	7
LP	5

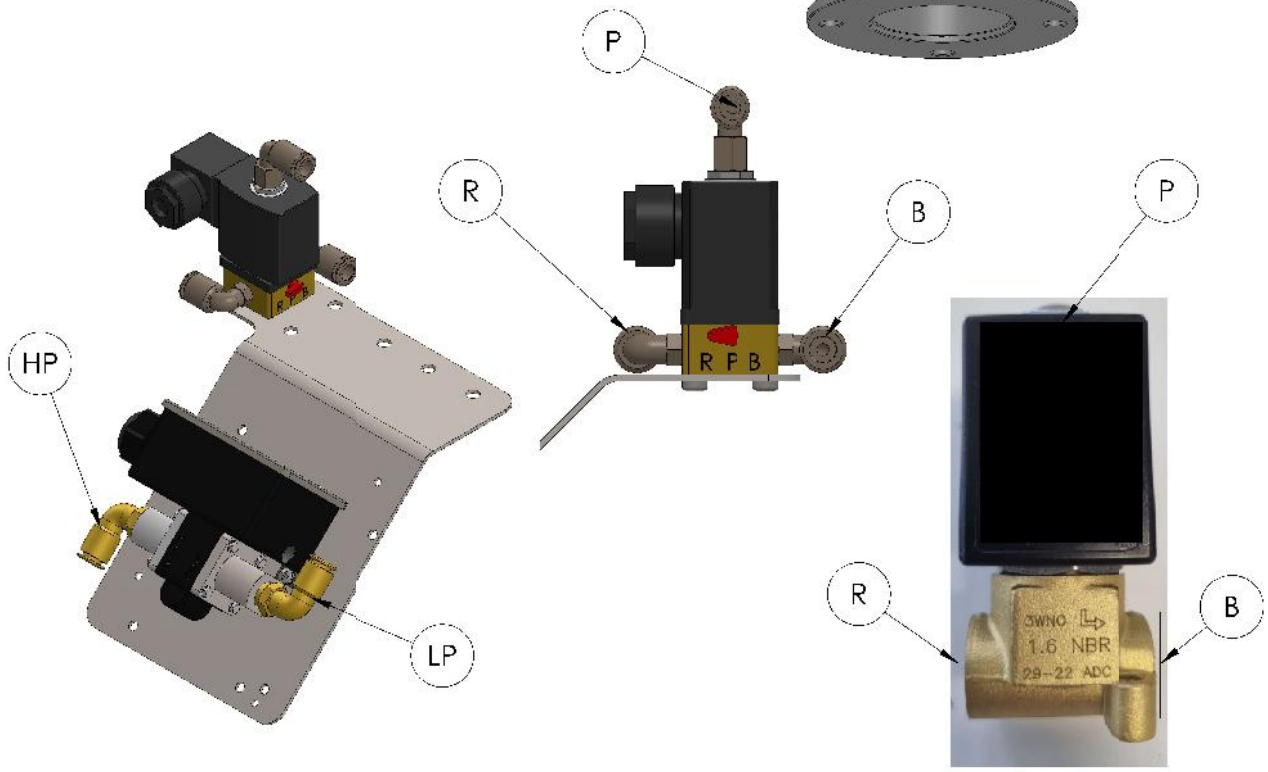
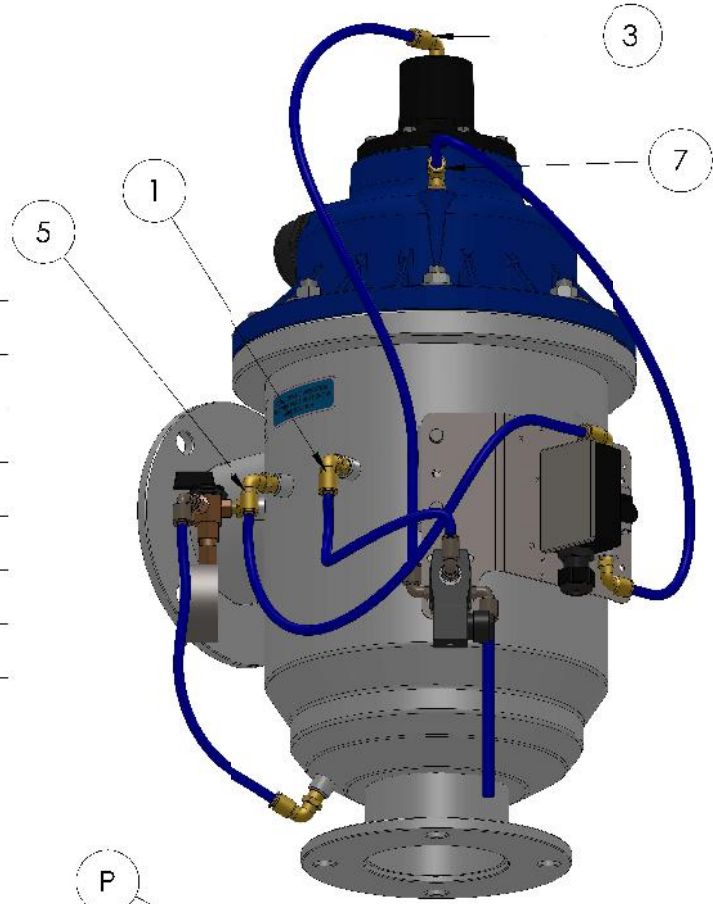

**PLC CONTROLLER CONNECTION**

## Coverlid

ITEM NO.	PartNo	Description	QTY.
1	P-16003	FILTER COVER LID	1
2	A-18040	EXHAUST VALVE ASSEMBLY	1
3	P-1100	DIAPHRAGM	1
4	P-1200	DIAPHRAGM COVER	1
5	P-13003	2" BSPT TO 1.5" BSPT F-FX REDUCING NIPPLE	1
6	P-14016	M6 Flat Washer - 304 S.S	8
7	P-14013	M6 X 35 GRUB SCREW, 304 ST/ST	8
8	P-11505	BS448 O-Ring	1
9	P-14713-4	1/4" BSPT - 8mm Elbow Fitting	2
10	P-14714-4	0.25 INCH BSPT PLUG - BRASS PLATED	1
11	P-1300	LOCKING RING	1
12	P-13002	SPRING SUPPORT	1
13	P-17010	SPRING	1
14	P-14018	M6X1 HEX NUT NYLOC	8

**NOTE:**

- ITEM 9, 10 AND 11, USE TEFLON TAPE ON ASSEMBLY
- For ITEM 10:  
Use P-14712-4 for Hydraulic Controlled Filter  
Use P-14713-4 for Electric Controlled Filter

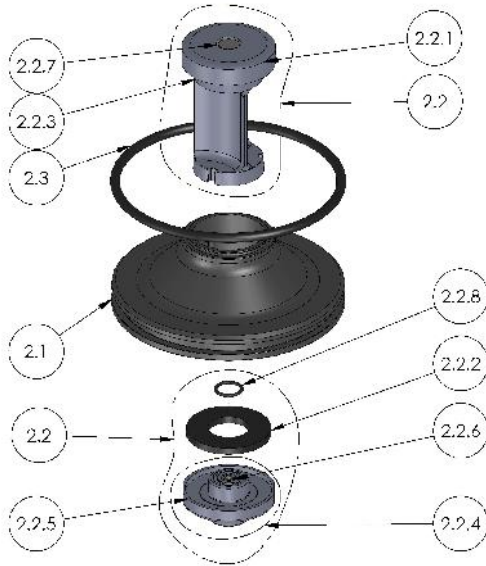

ITEM NO.	PartNo	Description	QTY.
2.1	P-18032	EXHAUST VALVE SEAT	1
2.2	A-18039	EXHAUST VALVE	1
2.2.1	P-18042	EXHAUST VALVE - TOP	1
2.2.2	P-18010	VALVE SEAT	2
2.2.3	P-18024	EXHAUST VALVE - GUIDE	1
2.2.4	A-18033	EXHAUST VALVE - BOTTOM	1
2.2.5	P-18033	EXHAUST VALVE	1
2.2.6	P-18027	INSERT OF BOTTOM BEARING	1
2.2.7	P-18044	M6x1 SET SCREW	1
2.2.8	P-11501	BS014 O-Ring	2
2.3	P-11503	3S 351 O-RING	1

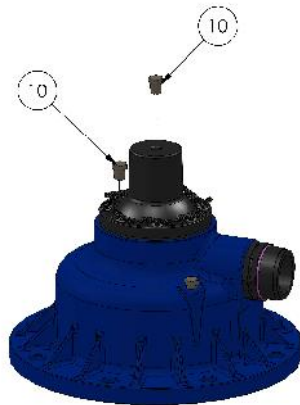
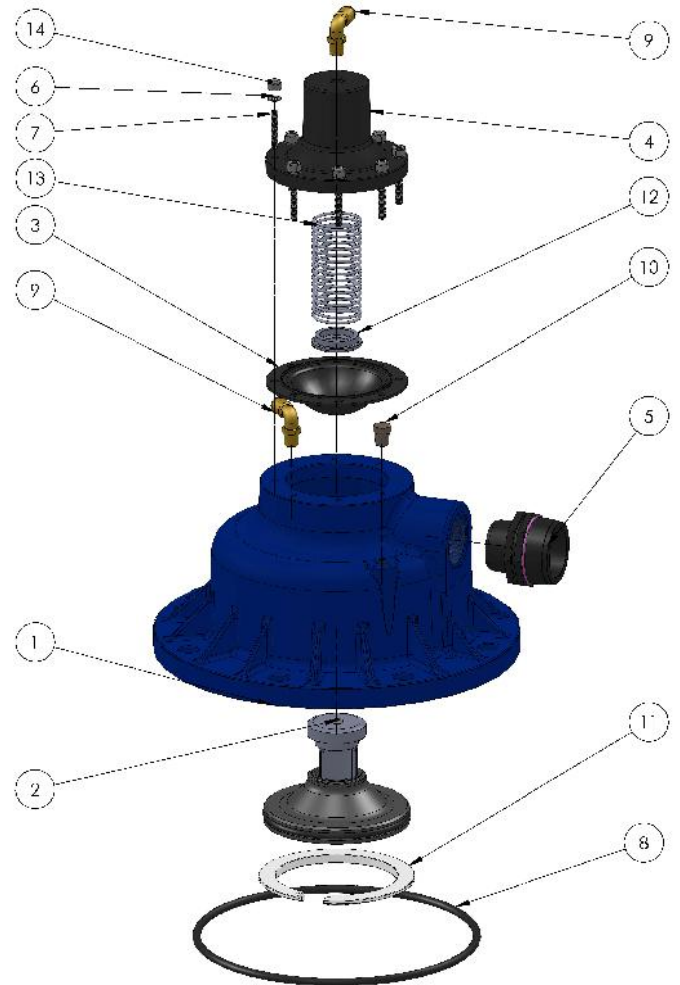

A-16005-N  
WITHOUT CONTROLLER

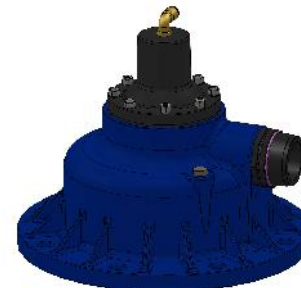

A-16005  
WITH CONTROLLER

# 1 Screen configurations parts Electric Control

ITEM NO.	PartNo	Description	Revision	QTY.
1		FW050 FILTER BODY WELDMENT	3	1
2	P-12005	SCREEN ASSEMBLY	0	1
3	A-16010-S	COVER LID & DIRT COLLECTOR	0	1
4	P-14003-1	1/2"UNC x 55LG STUD BOLT	-	8
5	P-14001-1	1/2" Flat Washer	-	8
6	P-14002-5	1/2" UNC Hex Nut	-	8
7	P-14017-1	M6 Spring Washer	-	2
8	P-14012-1	M6 x 10L Self Screw - Hex Head	-	2
9	P-15032	3-WAY TAP -PRESSURE GAUGE	-	1
10	P-14711-4	1/4" BSPT to 1/8" BSPT MALE REDUCING NIPPLE	-	1
11	P-15001	1000 kpa Gauge-Liquid Filled	0	1
12	P-14713-4	1/4" BSPT - 8mm Elbow Fitting	0	3
13	P-14730-4	1/8" BSPT -BMM ELBOW FITTINGS	-	1
14	P-14704-4	1/8" BSPT Plug	0	1
15	A-15142-E	ELECTRIC CONTROLLER ASSEMBLY	-	1
16	F111	Ø8mm FLEXIBLE TUBE	-	1m
17	15051	Product Label - Self Adhesive	-	1
18	15055	Filtaworx Registered Trade Mark-Self Adhesive	-	1
19	15053	Safety Caution Label - Self Adhesive	-	1
20	A-04205	FLANGE D&E FW050 FILTER BODY WELDMENT	3	1

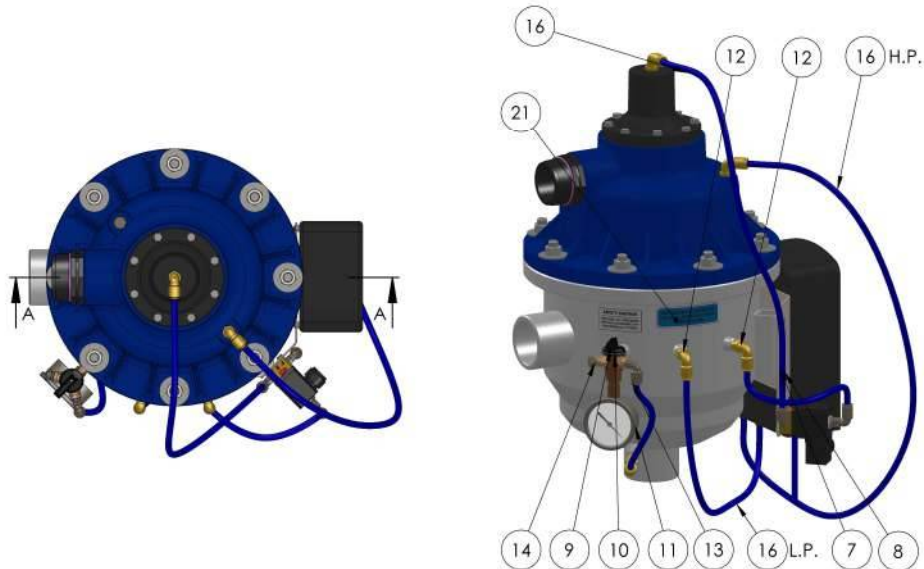
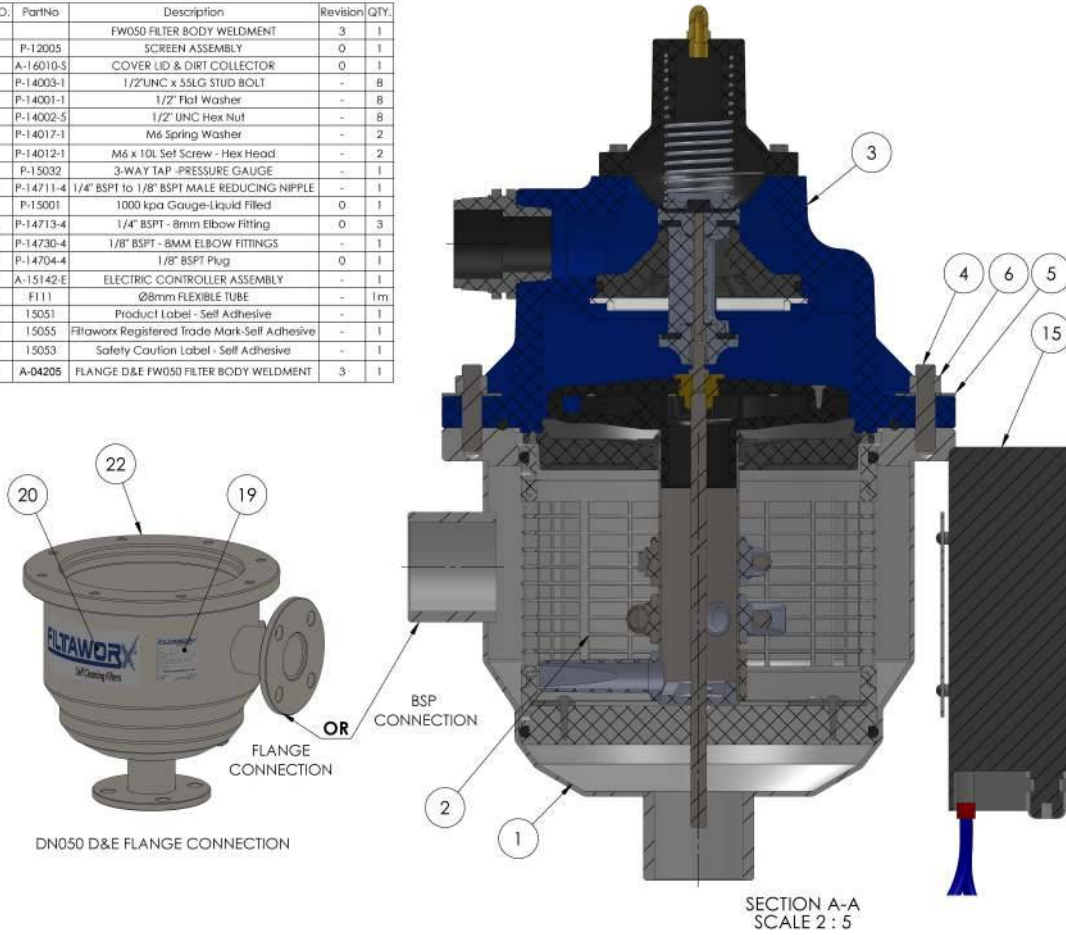

## 2 Screen configurations parts FW080EX-FW100

ITEM NO.	PartNo	Description	Revision	QTY.
1		FW100 FILTER BODY WELDMENT	0	1
2	A-12008	SCREEN ASSEMBLY	0	1
3	A-16011-S	COVER LID & DIRT COLLECTOR	0	1
4	P-14003-1	1/2" UNC x 55LG STUD BOLT	-	8
5	P-14001-1	1/2" Flat Washer	-	8
6	P-14002-5	1/2" UNC Hex Nut	-	8
7	A-15142-E	ELECTRIC CONTROLLER ASSEMBLY	-	1
8	P-14017-1	M6 Spring Washer	-	2
9	P-14012-1	M6 x 10L Set Screw - Hex Head	-	2
10	P-14711-4	1/4" BSPT to 1/8" BSPT MALE REDUCING NIPPLE	-	1
11	P-15032	3-WAY TAP - PRESSURE GAUGE	-	1
12	P-14713-4	1/4" BSPT - 8mm Elbow Fitting	0	3
13	P-14730-4	1/8" BSPT - 8MM ELBOW FITTINGS	-	1
14	P-14704-4	1/8" BSPT Plug	0	1
15	P-15001	1000 kpa Gauge-Liquid Filled	0	1
16	F111	Ø8mm FLEXIBLE TUBE	-	1m
17	15051	Product Label - Self Adhesive	-	1
18	15055	Filtawox Registered Trade Mark-Self Adhesive	-	1
19	15053	Safety Caution Label - Self Adhesive	-	1

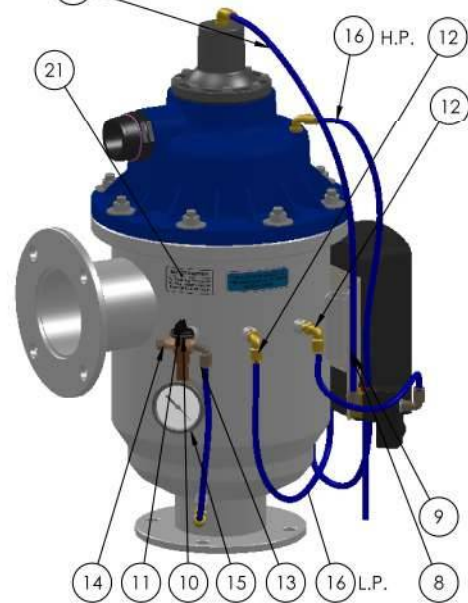
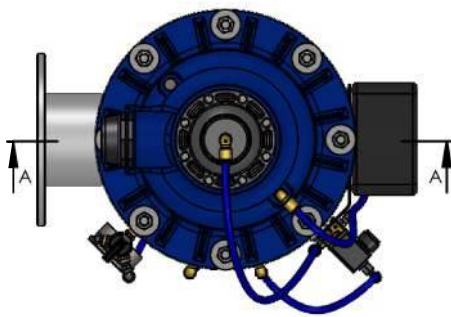
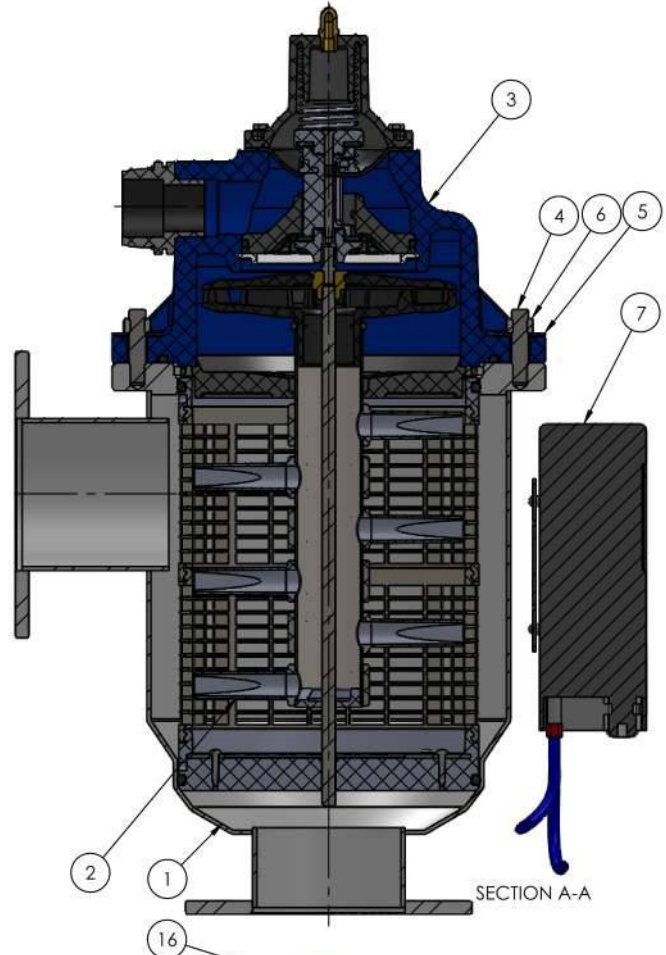

# Internal Parts for all diaphragm models

EM NO.	PartNo	Description	Revision	QTY.
1	A-16005	FILTER COVER LID ASSEMBLY	1	1
1.1	A-16005-N	FILTER COVER LID ASSEMBLY - NO CONTROLLER	0	1
2	A-19030	DIRT COLLECTOR	2	1
2.1	A-19031	DIRT COLLECTOR	0	1
5	P-14021	8G x 1/2" Length - Self Tapping Screw - Countersink Head	-	4

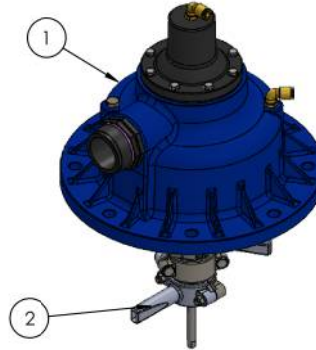
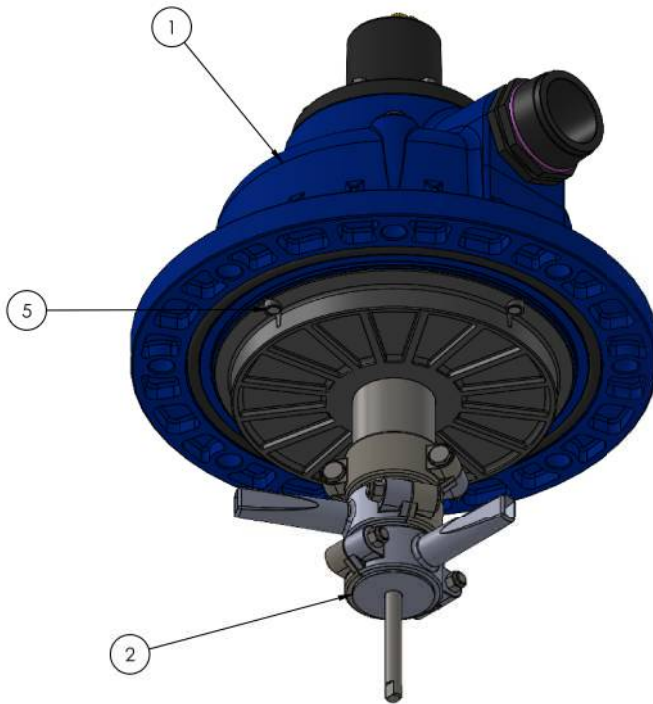

A-16010-E  
COVER LID - ELECTRIC / HYDRAULIC  
AND PLC CONTROL

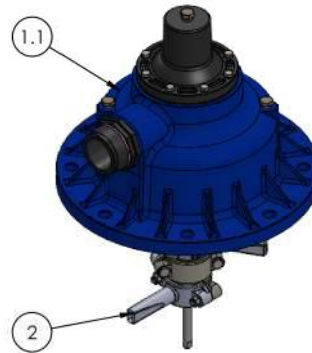

A-16010-N  
COVER LID - NO CONTROL

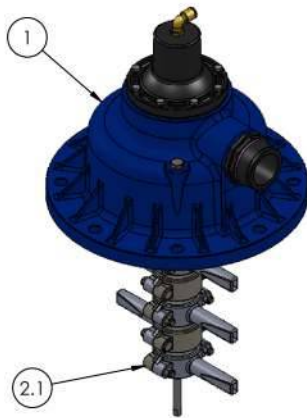

A-16011-E  
COVER LID - ELECTRIC / HYDRAULIC  
AND PLC CONTROL

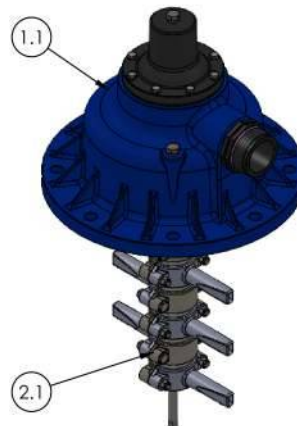

A-16011-N  
COVER LID - NO CONTROL

## Dirt Collector

ITEM NO.	PartNo	Description	Revision	QTY.
1	P-12006	PARTITION	3	1
2	A-19003	ROTOR SUB-ASSEMBLY	0	1
3	A-19020	DIRT COLLECTOR SUB-ASSEMBLY	3	1
3.1	A-19013	DIRT COLLECTOR SUB-ASSEMBLY	3	1
4	P-14005	8G x 3/8" L SELF TAPPING SCREW -PAN HEAD	-	4

**NOTE:**

FILE THE TIPS OF THE NOZZLES DOWN IF REQUIRED.

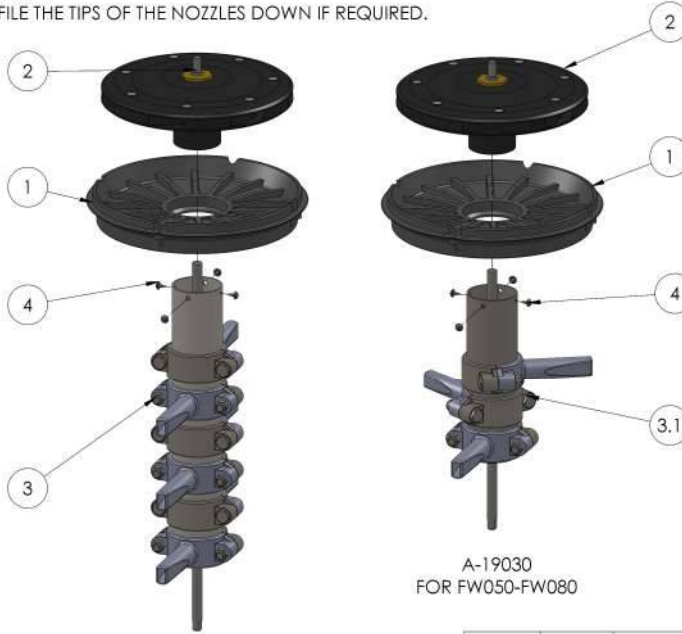

A-19031  
FOR FW080EX-FW100

A-19030  
FOR FW050-FW080

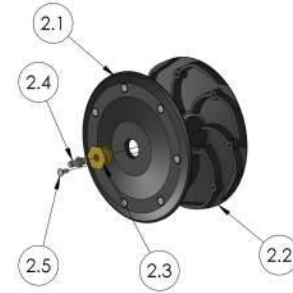

ITEM NO.	PartNo	Description	QTY.
2.1	P-19001	ROTOR COVER	1
2.2	P-19002	ROTOR	1
2.3	P-19004	BEARING HOUSING	1
2.4	P-19005	LOWER BEARING	1
2.5	P-14020	C10x0.75 X16MM LG	7

ITEM NO.	PartNo	Description	QTY.
3.1	P-19019	DIRT COLLECTOR TUBE	1
3.2	P-19015	DIRT COLLECTOR PLUG	1
3.3	P-14021	8G x 1/2" Length - Self Tapping Screw - Countersink Head	2
3.4	P-19021	DIRT COLLECTOR SHAFT	1
3.5	A-19010	NOZZLE SUB-ASSEMBLY	6

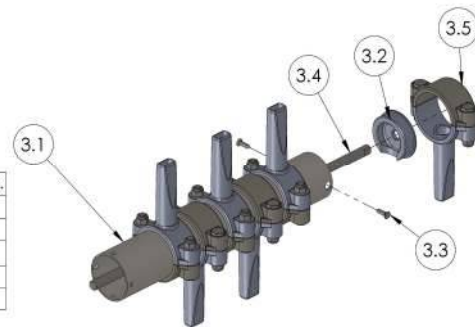

ITEM NO.	PartNo	Description	QTY.
3.1.1	P-19014	DIRT COLLECTOR TUBE	1
3.1.2	P-19015	DIRT COLLECTOR PLUG	1
3.1.3	P-14021	8G x 1/2" Length - Self Tapping Screw - Countersink Head	2
3.1.4	A-19010	NOZZLE SUB-ASSEMBLY	3
3.1.5	P-19016	DIRT COLLECTOR SHAFT	1



ITEM NO.	PartNo	Description	Revision	QTY.
1	P-12002	FINE SCREEN	12	1
2	P-12003	COARSE SCREEN	5	1
3	P-12004	O-RING HOUSING	5	1
4	P-11504	BS445A O-Ring (Special Soft)	0	2
5	P-17011	FIXING PLATE	1	2
6	P-12005	10Gx1" Self Tapping Screw - Pan Head	-	4

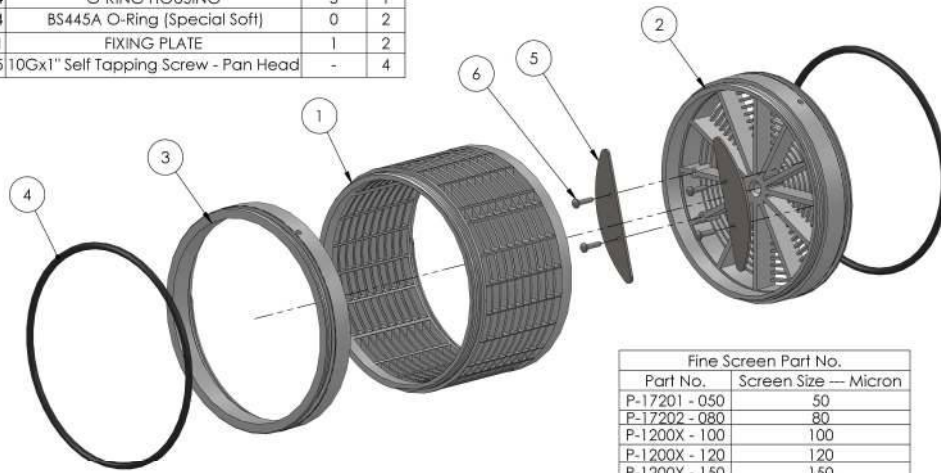

Fine Screen Part No.	
Part No.	Screen Size — Micron
P-17201 - 050	50
P-17202 - 080	80
P-1200X - 100	100
P-1200X - 120	120
P-1200X - 150	150
P-1200X - 200	200
P-1200X - 400	400
P-1200X - 800	800

P-1200X - XX  
 ↑                    ↑  
 12005            SCREEN SIZE  
 12008



P-17201  
FINE SCREEN  
FOR FW050-FW080

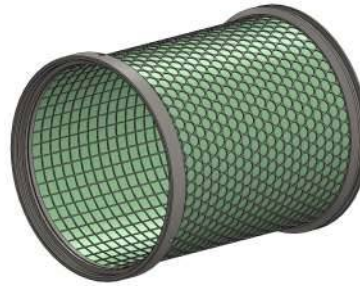

P-17202  
FINE SCREEN  
FOR FW080EX-FW100



A-12005  
FOR FW50 - FW80



A-12008  
FOR FW080EX - FW100

## Screen Removal Instructions

1. SQUEEZE EXTRACTION TOOL AND MOVE IT INTO THE FINE SCREEN AS SHOWN.

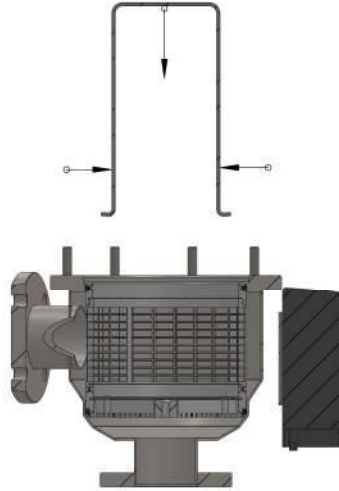

2. INSERT THE FEET OF EXTRACTION TOOL BELOW THE COARSE SCREEN STOP PLATES, THEN RELEASE EXTRACTION TOOL SO BOTH FEET SIT UNDER COARSE SCREEN STOP PLATES.

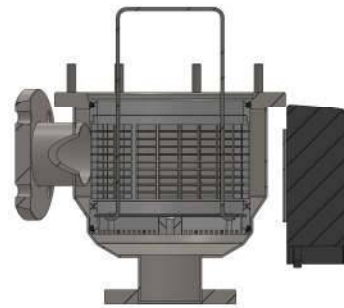

3. PULL OUT THE FINE SCREEN FROM THE BODY.

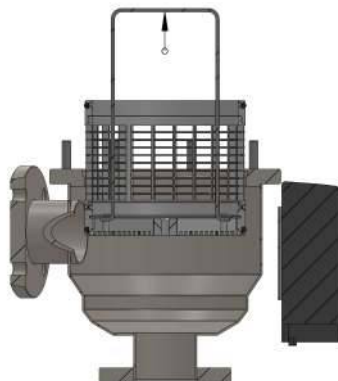

## NNEX A: Filter Data Sheets

Please see filter data sheets below:

Model No.	FW050	FW050F	FW080	FW080F	FW80EX	FW100
Inlet / Outlet						
Nominal size mm/inch	50 / 2"	50 / 2"	80 / 3"	80 / 3"	80 / 3"	100 / 4"
Connections	Threaded	Flanged	Threaded	Flanged	Flanged	Flanged
Min. operating pressure	200 kPa at all times (30 psi/2bar)					
Max. operating pressure	1000 kPa standard (150 psi/10 bar), higher available on request					
Filter Area	1220 cm <sup>2</sup>				1980 cm <sup>2</sup>	
Max. working temperature	65° C / 150° F					
<b>Flushing Data</b>						
Flush line size mm/inch	50 / 2"					
Flush cycle duration	5 – 7 seconds (depending on pressure)					
Flush cycle volume	30 litres approx (depending on pressure)					
Min. flow for backwash	14 m <sup>3</sup> /hr (4 l/sec) @ 200 kPa					
<b>Materials of Construction</b>						
Filter body	304 grade stainless steel (316 and other grades on request)					
Cover lid assembly	GRN (glass reinforced nylon), St/St, brass					
Cleaning mechanism assy.	St/St, brass, GRN					
Fine screen	316 St/St mesh, GRN					
Coarse screen	GRN					
Seals	NBR, EPDM					
Controller	St/St, brass, Acetal, PVC,					
Control tubing	Nylon					
<b>Weight kg (lbs)</b>						
Empty	22 (48.5)	23 (50.71)	22 (48.5)	25 (55)	30 (66)	
Full	42 (92.6)	43 (94.8)	42 (92.6)	45 (99.2)	57 (126)	



IT

Reserved for future product development

## ANNEX B: Filter Dimensional Data

26. Please see below table showing dimensional data:

Model No.	Nominal Size D		Inlet & Outlet Connectors	Nominal Flow at 2m Head Loss		Filter Area		Dimensions								Weight					
	Inch	mm		L/sec	m <sup>3</sup> /hr	cm <sup>2</sup>	in <sup>2</sup>	A		B		C		X		Y		Empty		Full	
								mm	inches	mm	inches	mm	inches	mm	inches	mm	inches	kg	lbs	kg	lbs
FW 050	2	50	7	25	1220	189.1	184	7.24	198	7.80	204	8.03	720	28.35	560	22.05	22	10	42	19	
FW 050-F	2	50	7	25	1220	189.1	210	8.27	210	8.27	204	8.03	720	28.35	575	22.64	23	10	43	43	
FW 080	3	80	14	50	1220	189.1	194	7.64	213	8.39	204	8.03	720	28.35	575	22.64	22	10	42	42	
FW 080-F	3	80	14	50	1220	189.1	210	8.27	210	8.27	204	8.03	720	28.35	575	22.64	25	11	45	45	
FW080EX	3	80	22	80	1980	307	235	9.25	315	12.40	215	8.46	900	35.43	690	27.17	30	14	57	57	
FW 100	4	100	22	80	1980	307	235	9.25	315	12.40	215	8.46	900	35.43	690	27.17	30	14	57	57	

IT

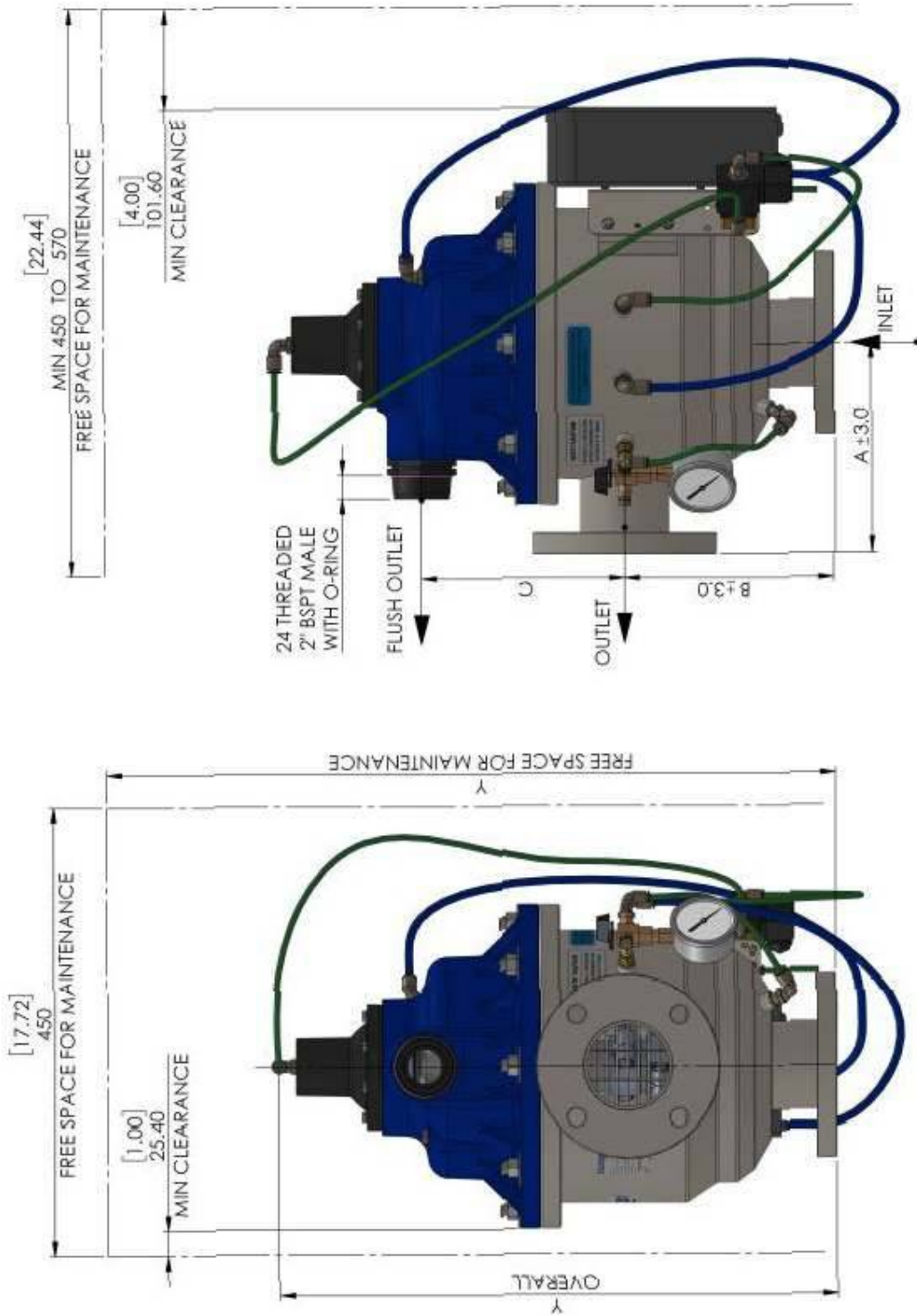

## Warranty

The manufacturer warrants the product only against defects in material and workmanship for (2) years from date of dispatch. This limited warranty is valid only when the product is used in accordance with the manufacturer's standards and instructions and on condition that the customer fulfils his/her obligations set forth in this manual. The manufacturer's liability is limited to the replacement of defective parts with new or rebuilt parts, free of charge.

This warranty is extended only to the original purchaser. A purchase receipt or other proof of date of original purchase is required before warranty performance is rendered.

This warranty only covers failures due to defects in materials or workmanship, which occur during normal use. It does not cover damage caused by accidents, misuse, abuse, neglect, mishandling, misapplication, alteration, modification or service by anyone other than the manufacturer or any person/agent authorized by the manufacturer.

The manufacturer is not liable for incidental or consequential damages resulting from the use of this product or arising out of any breach of this warranty. All express and implied warranties, including the warranties of merchantability and fitness for a particular purpose, are limited to the applicable warranty period set forth above.

Faulty replaced parts are to be returned to Triangle Waterquip for inspection and assessment, so they in turn can claim warranty replacements from the manufacturer.

If you have any questions, contact your local dealer or our service department.



07 - 2022

**HELIX**   
**HYDRO**

**T:** 03 9580 2122

**W:** [helixhydro.com.au](http://helixhydro.com.au)

**E:** [sales@helixhydro.com.au](mailto:sales@helixhydro.com.au)

**A:** 23 Sir Laurence Drive, Seaford, Vic 3198

VIC/TAS

P: 0427 033 967

WA/NT

P: 0409 115 895

NSW/ACT

P: 0414 675 663

QLD

P: 0417 733 508

SA

P: 0427 033 967



AUSTRALIAN  
OWNED AND  
OPERATED