

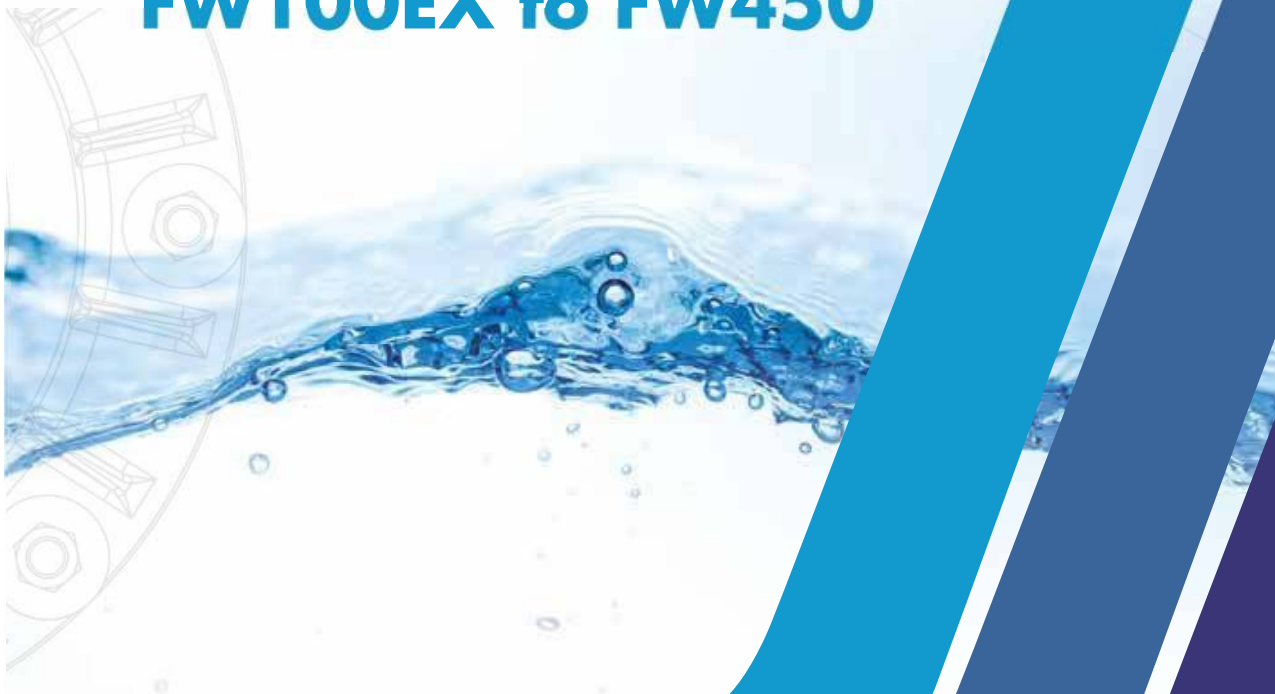


**HELIX**  
HYDRO



**FILTAWORX**  
*Self Cleaning Filters*

**AUTOMATIC FILTER  
OPERATIONS MANUAL  
FW100EX to FW450**



# TABLE OF CONTENTS

<b>Safety Warnings</b> .....	<b>1</b>
<b>Introduction And Installation</b> .....	<b>2</b>
Introduction.....	2
Filter Components.....	2
Operation.....	2
Filter Installation.....	5
Filter Commissioning.....	6
<b>Operating Instructions</b> .....	<b>7</b>
General Operations.....	7
Maintenance Schedule.....	7
Opening the filter for inspection.....	9
Trouble Shooting.....	10
<b>Spare Parts</b> .....	<b>11</b>
Common Spare parts for all Filter Sizes.....	11
Coverlids.....	22
Filter Configurations.....	23
6 Screen configurations parts FW100EX-FW150.....	24
9 Screen configurations parts FW150EX-FW250.....	27
Screen configurations parts FW250EX-300.....	28
Screen configurations parts FW350-400.....	29
Screen configurations parts FW450.....	30
<b>Annexes</b> .....	<b>31</b>

## LIST OF ANNEXES

ANNEX A Filter Data Sheets.....	31
ANNEX B Filter Dimensional Data.....	32
Warranty.....	33

# SAFETY WARNINGS



In operation the filters will contain pressurised water, this must be released prior to any operation accessing the filter internals or control tubes.



In operation the filter is connected to pressure piping, the filter must be isolated from the piping, both upstream and downstream, prior to operation accessing the filter internals or control tubes.



Residual water will remain in the filter when opened, ensure this is contained so it does not flow to any electrical connections or cabling.



Even with the pressure released from the filter, the control lines may still hold some pressure, on release ensure any spray is not directed to electrical equipment or personnel.



The water contained in the filter may have been stored for some time and is stagnant or from a contaminated source.

In all operations wear protective gloves and eye protection. Avoid touching bare skin after exposure to the water.



When disassembling the filter, many components are heavy and difficult to lift. Ensure you have assistance or applicable lifting equipment available.

In all operations wear protective gloves, foot and eye protection.

**Failure to comply may result in severe injury or death to personnel and damage to equipment.**

## List of Abbreviations

DP	Differential Pressure
B.o.M	Bill of Materials
A	Assembly
P	Part / Component

# INTRODUCTION AND INSTALLATION

## Introduction

1. Congratulations on purchasing a Filtaworx® automatic self-cleaning filter. Filtaworx® filters are manufactured from the highest grade materials and supported by a comprehensive quality program to ensure a long trouble free operation
2. Please read the following manual carefully and follow all instructions to obtain the best performance from your filter.

## Filter Components

3. Please see Figure 1 below indicating the main filter components:

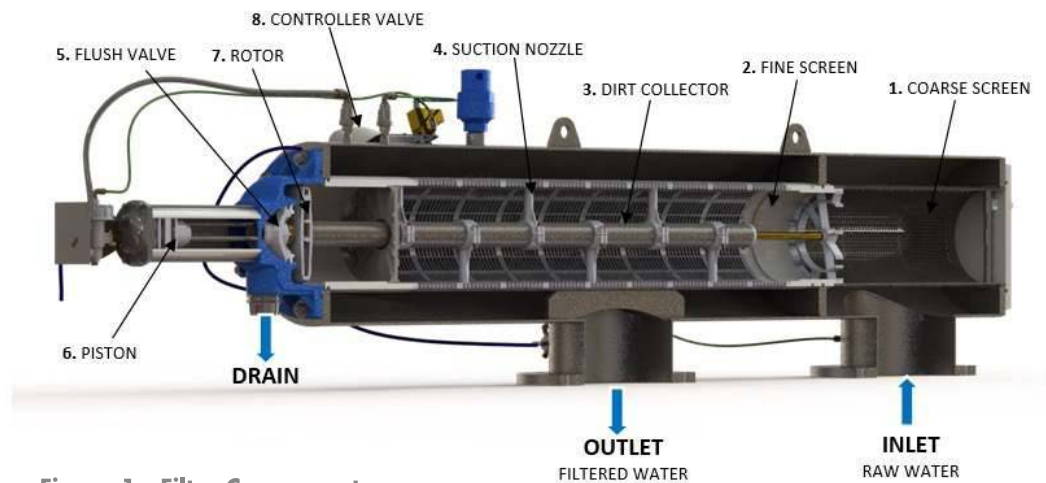


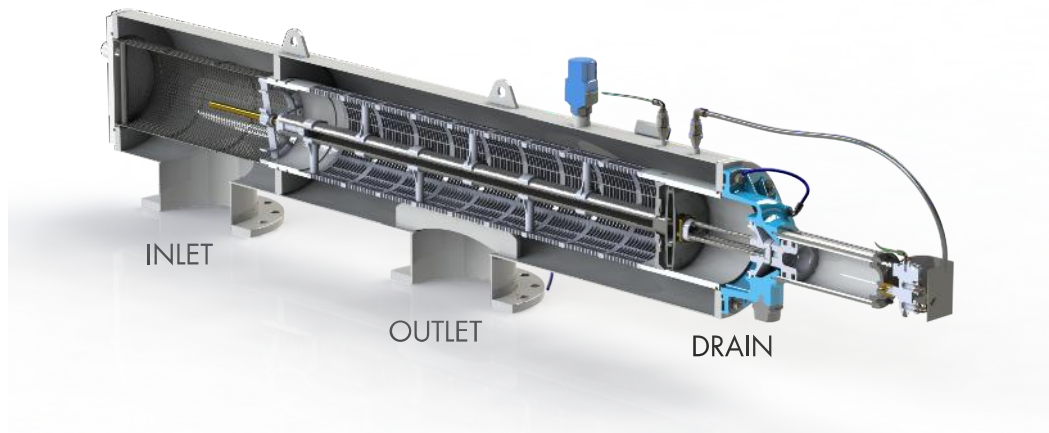
Figure 1 - Filter Components

## Operation

4. Filtaworx® automatic filters have a self-cleaning function. When activated a filter flush will occur, the internal nozzles travel over the screen internal, vacuuming the filter fine screen, the contaminates are ejected from the drainpipe. Typically, this operation is triggered by a differential pressure (DP) across the filter of 50 kPa (7 psi). Each operation of the flush should take between 15-17 seconds. While flushing, the filter continues to operate normally with clean water exiting the outlet.
5. The flush can be triggered three ways depending on the control supplied:
  - a. Hydraulic control - a diaphragm in the rinse controller will send the system into flush at 50 kPa (7 psi). This is factory set and cannot be adjusted.
  - b. Electric Control - a control module will monitor the DP, activating a solenoid to send the system into flush, factory set to 50 kPa (7 psi), this can be adjusted, additionally the current DP is displayed. This controller will also allow for flush activation on a settable time interval regardless of the DP
  - c. PLC control - a normally open pressure switch will close at set DP, factory set at 50 kPa (7 psi), signalling the PLC (not supplied) a flush is required. When downstream operations allow, the PLC will send a signal to activate a solenoid to send the system into flush.

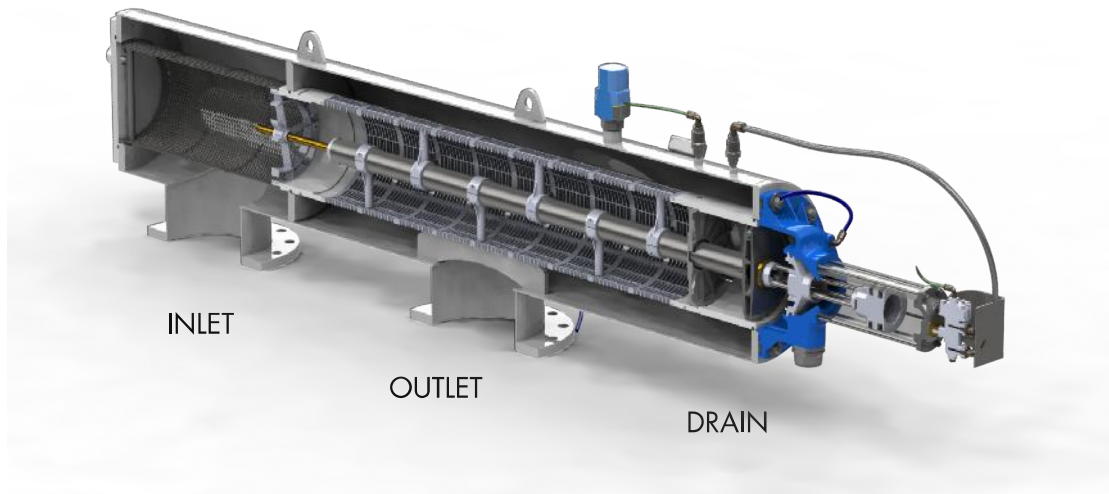
6. Flush operation:

- a. Filter in steady state normal operation with piston in standard position with no flush operation, the drain valve is closed. Water flows from inlet to outlet only. See Figure 2 below.



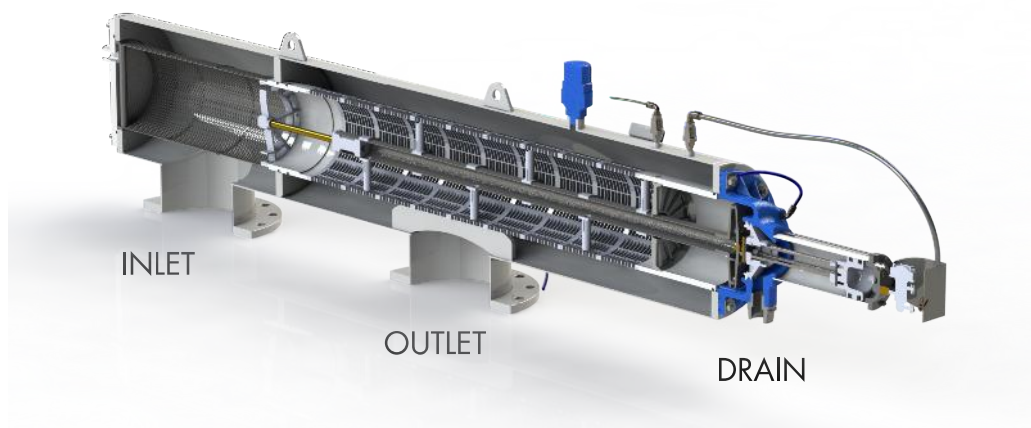
**Figure 2** Piston in steady state position, drain closed.

- b. Filter enters flush, the piston moves away from steady state position, this opens the drain valve and flush begins. Water will now flow from inlet to both outlet and drain, thus a slight loss of pressure and flow to main outlet. See Figure 3 below.



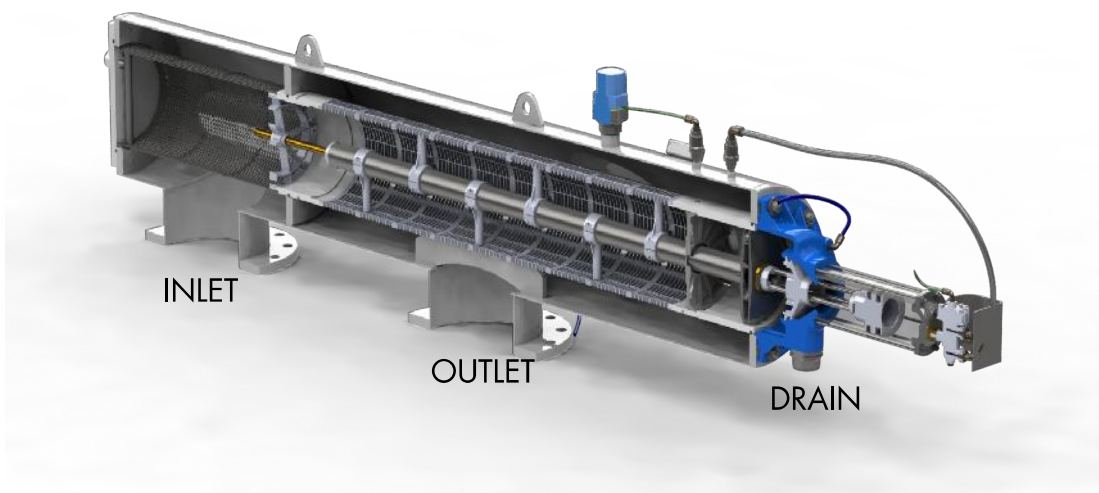
**Figure 3** Piston with drain open.

- c. When the piston reaches the end of its stroke, the drain will close again, flush will pause, but is not complete. See Figure 4 below.

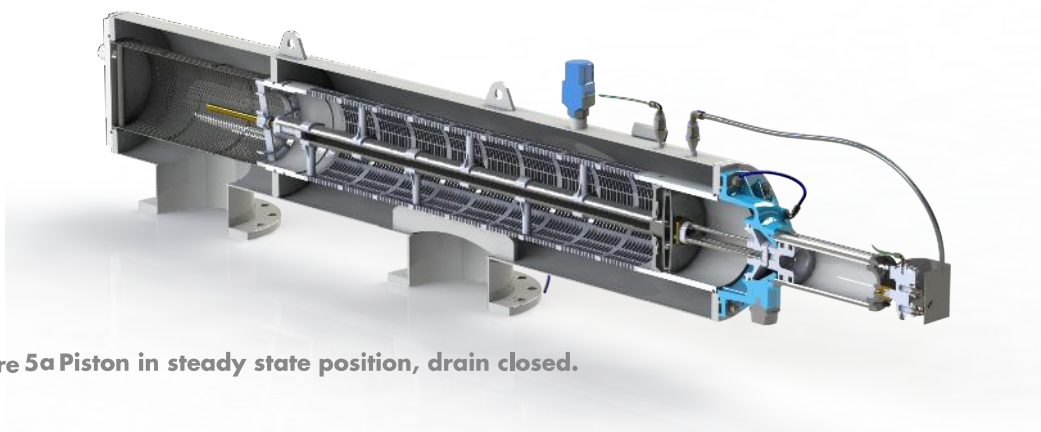


**Figure 4** Piston at end of stroke, drain closed.

- d. The piston will now return to steady state position, again opening the drain valve, giving the fine screen additional cleaning. Operation is now complete. See Figure 5 and 5a below.



**Figure 5** Piston going back in steady state position, drain open.



**Figure 5a** Piston in steady state position, drain closed.

## Filter Installation

7. Please see Figure 6 below for a typical installation, the filter can be installed in any orientation and the cover lid can be rotated to suit drain exit. Please note the critical items below.

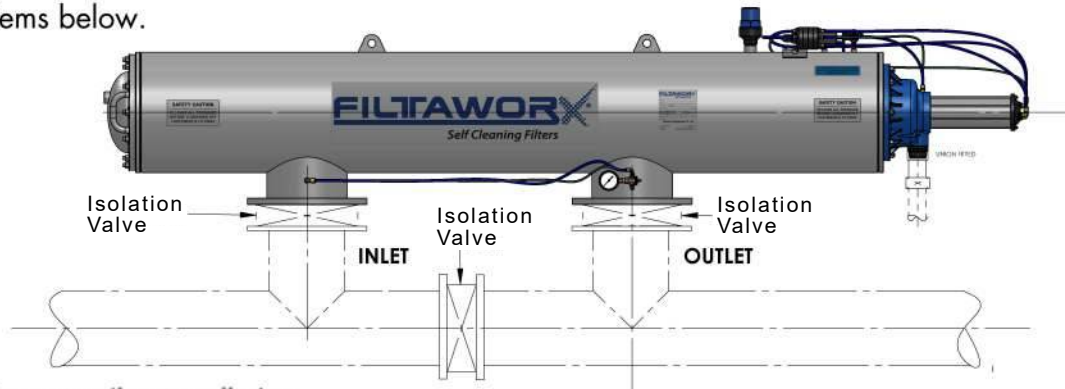


Figure 6 - Filter Installation

- a. The filter is delivered tested and in operational condition. Only items that must be fitted prior to use other than piping are:
  - i. Fit the air release valve, this is supplied loose for packing.
  - ii. For Electric Control connect to mains power or fit batteries, if required for DC models.
  - iii. For PLC control, connect PLC cables as required.
- b. Isolation valves at inlet and outlet.
- c. Barrel union fitted to drain line for easy removal of coverlid during service.
- d. Drain pipework is a minimum DN50 (2") to prevent back pressure. If the drain is longer than 10m, use DN80 (3") pipework.
- e. Drain line is down hill only with minimum length.
- f. Ensure sufficient service space around the filter as per dimension in Annex B.
- g. During flush, water will also drain from below. This can be piped away but ensure little to no back pressure.
  - i. Rinse controller, DN25 (1") BSP piping.
  - ii. Electric and PLC control 8mm nylon tubing.
- h. Ensure water will not flow backwards through the filter, this can damage the fine screen.
- i. A bypass line for critical installations but would strongly recommend a backup filter to protect downstream infrastructure.
- j. For PLC only: The PLC (not supplied by Filtaworx®) will be used to control the flush of the filter, it must be programmed:
  - i. A close signal from the pressure switch on the filter will indicate a flush is needed. PLC to then ignore all signals from DP switch until after flush.
  - ii. As soon as possible after this signal the PLC must send a 24V (AC or DC specified by user) to the solenoid on the filter, and held on for 15 seconds.
  - iii. The PLC will ignore all signals from the pressure switch for 30 seconds after the solenoid signal has finished to allow the flush to complete and turbulence to subside.

## Filter Commissioning

8. Once the filter is installed, and pressure is available, the filter is ready to commission.
9. Fill the filter with water, close the outlet valve and part open the inlet, you will hear air leaving the air release valve. This will take a few minutes. See Figure 7 below.
10. Note the piston may move to the steady state position during this process and some water may go through the drain, once pressure builds up in the filter.

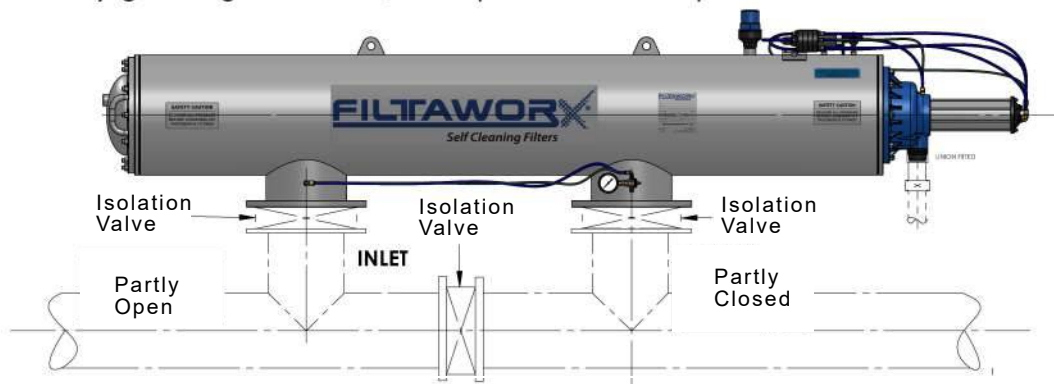


Figure 7 - Filter Fill with Water

11. Once the filter is filled with water and pressurised, check and fix any connection leaks at flanges and drain connection.
  - a. On Hydraulic controlled units make sure 3 way tap is pointing to Auto. See Figure 8.
  - b. No action required for other controllers.

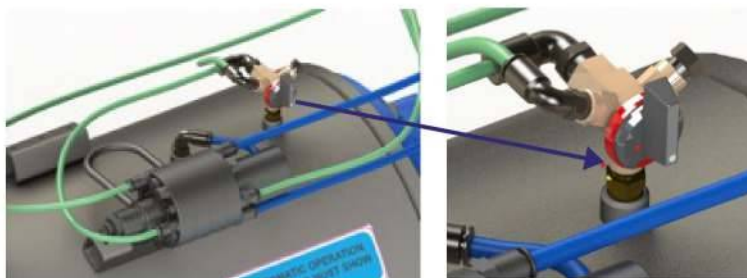


Figure 8 - 3 Way Tap in Auto Position

12. Open the inlet valve fully, keep the outlet valve closed, and do a test flush:
  - a. Hydraulic control, turn the 3-way tap from Auto to Open, wait 1-2 seconds, return to Auto. See Figure 9 below. Note water will eject from the drain line



Figure 9 - Tap turned to open, then back to Auto, for flush

- b. Electric control, press the "M" button on the controller, may need to press twice, first to enable display.
  - c. PLC, will need to request PLC send signal to solenoid.
13. During the first flush the system may cause some water hammer during the flush, as the air is removed. Repeat 2 or 3 more flushes to remove all air and initialise the filter.
14. Slowly open the outlet valve to let the water flow through the filter.
15. Do another manual flush as per item 12. The system is now operational.

# OPERATING INSTRUCTIONS

## General Operations

16. Once installed the Filtaworx® Automatic Filter will work automatically and requires very little user input.
17. The filter inlet and outlet pressures can be checked with the connected pressure gauge. This can be used as per below.
  - a. To check inlet (dirty water side) pressure, turn the 3-way tap to the hose connector as per Figure 10 below.



**Figure 10 - Tap turned for inlet pressure.**

- b. To check outlet (clean water side) pressure, turn the 3-way tap to the filter as per Figure 11 below;



**Figure 11 - Tap turned to outlet pressure.**

18. A manual flush can be initiated by following the instructions in item 12.



## Maintenance Schedule




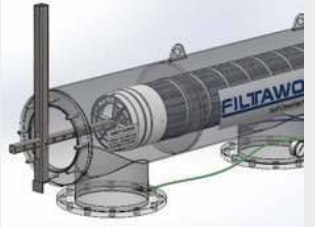





19. Follow the maintenance and inspection schedule as per table below. The frequency indicated is for a filter in low to moderate conditions, that would normally auto flush every few hours.
20. If the filter is flushing more regularly in heavy conditions, then increase the frequency of the checks. Note water contamination will change due to environmental conditions such as flooding or extended high temperatures.
21. Please refer to the parts breakdown for location of the items mentioned below.

No.	Item	Frequency	Inspection Task.
1	Flushing	Once per 2 weeks	Manual flush the filter and check inlet/outlet pressure before and after flush to ensure cleaning is operating correctly.
2	Coarse screen	Once per 6 months / 12 months	Remove and clean the coarse screen from the filter, if only small build up this can be extended to 12-month frequency
3	Fine Screen	Once per 6 months / 12 months	Remove inspect and clean the fine screen from filter, if only small build up this can be extended to 12-month frequency
4	Upper and lower bearing	Once per 12 months	Inspect for wear, replace if needed
5	Coverlid	Once per 12 months	Check that the piston moves smoothly up and down
6	Piston Seals	Once per 12 months	Check for wear, replace if needed
7	Seal Washer	Once per 12 months	Check for wear, replace if required
8	Anode	Once per 6 months	Check for wear, replace if required

## Opening the filter for inspection

22. Please following the instructions below for opening the filter for inspection/ maintenance.

No.	Item	Frequency
1	Ensure you have read all safety warning at start of manual prior to proceeding.	
2	Ensure filter is running at pressure above 200Kpa (30 psi) and perform 3 manual flushes as per para 12 to clean filter.	
3	Close both inlet and outlet isolation valves, system pump may need to be shut down.	
4	Perform another manual flush, this will release the water pressure. Check the pressure gauge as per para 17, it should read zero.	

No.	Item	Frequency
5	If the pressure gauge does not read zero, flush again, investigate why pressure is trapped in the filter.	
6	With zero pressure, loosen but leave the top nut in place on the end cover, remove remaining bolts, water will drain out of the opening. Once drained remove the end cover.	
7	Remove the coarse screen on filters FW100EX to FW250 by reaching in and pulling on handlebar.	
8	Remove the fine screen on filters FW100EX to FW250 using the fine screen extraction tool. This will take some effort to dislodge the o-rings from seats.	
9	Remove the coarse screen and fine screen on filters FW250EX to FW450 by reaching in and pulling on handlebar, do not twist as this will disconnect the fine screen. This will take some effort to dislodge the o-rings from seats. A lever and strap may be required.	
10	The fine screen can be disconnected from the dirt collector using Filtaworx "C" spanners to unscrew. Once separated use a pressure cleaner to clean the fine screen, but only from the inside out. Pressure cleaning from the outside will damage the screen.	
11	Remove the flexible tubing from the coverlid, clearly label so it can be returned to original pipe fittings.	
12	Loosen but leave the top nut in place on the coverlid, remove remaining bolts, water will drain out of the opening. Once drained remove the coverlid.	
13	The filter is now broken down into its major parts, for further disassembly please refer to the parts section for exploded views.	

## Trouble Shooting

23. Please see below instructions for trouble shooting any issues with filter operation.

Problem	Possible Cause	Solution
Hydraulic control rinse controller continually draining	Filter has access material in fine screen	Check pressure gauge for DP, if over 50 kPa (7 psi) perform a manual clean on filter
	Rinse Controller has dirt built up not operating correctly	Check pressure gauge for DP, if over 50 kPa (7 psi) contact Distributor for parts
Drain valve not closing	Insufficient Pressure	Ensure the filter has over 200 kPa (30 psi) of pressure
	Control tube blocked	Check all control tubes to piston end cover
	Seal washer damaged	Remove coverlid and check seal washer
	Bearing failed	Remove coverlid and check bearings
	Piston is jammed	Remove coverlid and check piston movement
Continuous flushing	Filter has excess material in fine screen	Check pressure gauge for DP, if over 50 kPa (7 psi) perform a manual clean on filter
	Rinse Controller has dirt build up not operating correctly	Check pressure gauge for DP, if over 50 kPa (7 psi) contact Distributor for parts
	Electric Controller has dirt build up not operating correctly	Check DP on screen, it should be similar to gauge and constraint. If not contact Distributor for parts
No flow though filter	Filter is blocked due to not self-cleaning.	<p>Check pressure gauge for DP, if over 50 kPa (7 psi) try a manual clean a number of times. If this cleans the filter:</p> <ul style="list-style-type: none"> <li>• Check control tubes for blockages</li> <li>• Check the DP on the Electric controller is accurate and 0.5 bar is set for the flush point</li> <li>• On electric control and PLC ensure the solenoid is operating and has no blockage</li> </ul> <p>Check pressure gauge for DP, if over 50 kPa (7 psi) try a manual clean a number of times. If this does not clean the filter:</p> <ul style="list-style-type: none"> <li>• Filter is overloaded and cannot clean organic matter, do manual clean</li> <li>• Filter has an internal failure, disassemble, and investigate</li> </ul>

## SPARE PARTS

### Common Spare parts for all Filter Sizes

24. Control system layout:

HYDRAULIC CONTROLLER



ELECTRIC CONTROLLER



NO CONTROLLER



PLC CONTROLLER



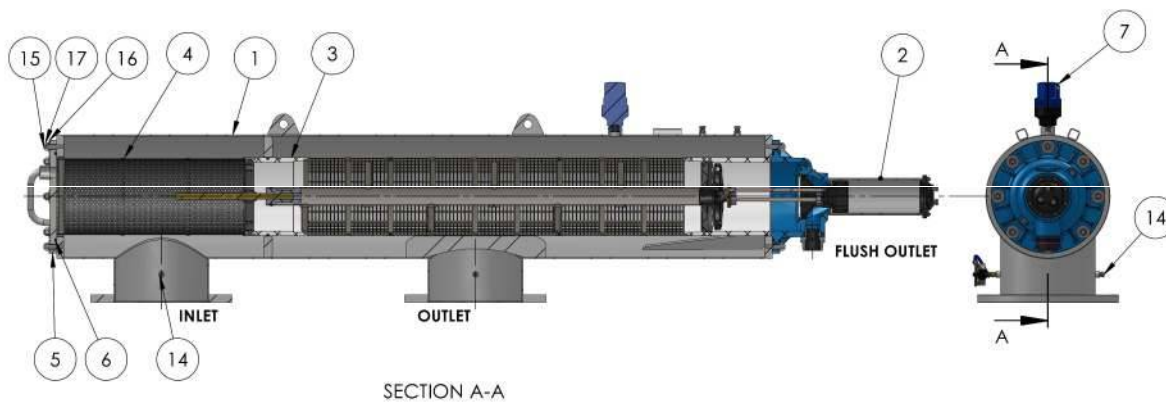
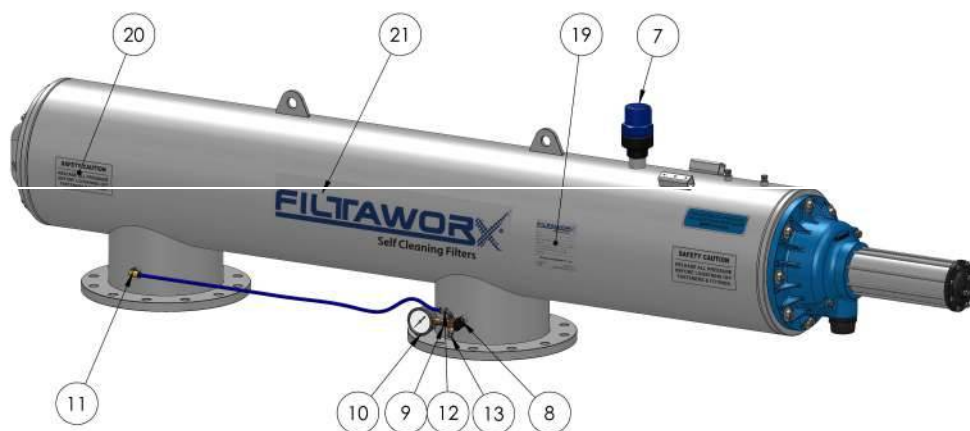
## NO CONTROL

ITEM NO.	PartNo	Description	Revision	QTY.
1		BODY FABRICATION	6	1
2		End Cover	0	1
3		FINE SCREEN & DIRT	0	1
4		COARSE SCREEN	2	1
5		END COVER	0	1
6	P-11505	BS448 O-Ring	-	1
7	P-15005	AIR RELEASE VALVE - 1" BSP	-	1
8	P-14711-4	1/4" BSPT to 1/8" BSPT MALE REDUCING NIPPLE	-	1
9	P-15032	3-WAY TAP -PRESSURE GAUGE	-	1
10	P-15001	1000 kpa Gauge-Liquid Filled	0	1
11	P-14713-4	1/4" BSPT - 8mm Elbow Fitting	0	1

ITEM NO.	PartNo	Description	Revision	QTY.
12	P-14730-4	1/8" BSPT - 8MM ELBOW FITTINGS	-	1
13	P-14704-4	1/8" BSPT Plug	0	1
14	P-14714-4	0.25 INCH BSPT PLUG -BRASS PLATED	0	4
15	P-14003-1	1/2"UNC x 55LG STUD BOLT	-	16
16	P-14001-1	1/2" Flat Washer	-	16
17	P-14002-5	1/2" UNC Hex Nut	-	16
18	15051	Product Label - Self Adhesive	-	1
19	15053	Safety Caution Label - Self Adhesive	-	4
20	15054	Filtaworx Trade Mark Label - Self Adhesive	-	2
21	F111	Ø8mm FLEXIBLE TUBE	-	1

**NOTE**

1. TYPICAL BOM ARRANGEMENT FOR NO CONTROLLER

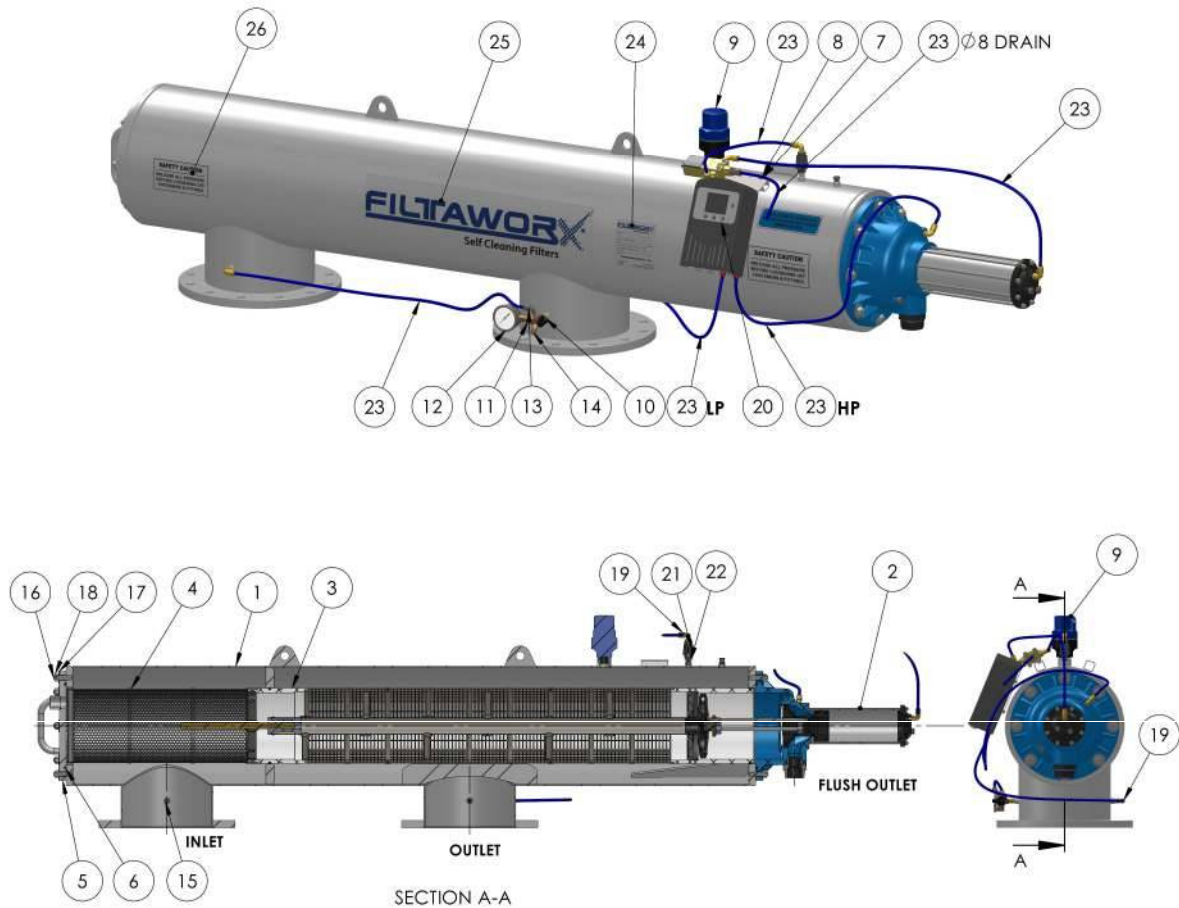


## ELECTRIC CONTROL

ITEM NO.	PartNo	Description	Revision	QTY.
1		BODY FABRICATION	6	1
2	A-21016-ES	End Cover	0	1
3		FINE SCREEN & DIRT	0	1
4		COARSE SCREEN	2	1
5		END COVER	0	1
6	P-11505	B548 O-Ring	-	1
7	P-14017-1	M6 Spring Washer	-	2
8	P-14012-1	M6 x 10L Set Screw - Hex Head	-	2
9	P-15005	AIR RELEASE VALVE - 1" BSP	-	1
10	P-14711-4	1/4" BSPT to 1/8" BSPT MALE REDUCING NIPPLE	-	1
11	P-15032	3-WAY TAP -PRESSURE GAUGE	-	1
12	P-15001	1000 kpa Gauge-Liquid Filled	0	1
13	P-14730-4	1/8" BSPT - BMM ELBOW FITTINGS	-	1
14	P-14704-4	1/8" BSPT Plug	0	1
15	P-14714-4	0.25 INCH BSPT PLUG -BRASS PLATED	0	2

ITEM NO.	PartNo	Description	Revision	QTY.
16	P-14003-1	1/2"UNC x 55LG STUD BOLT	-	16
17	P-14001-1	1/2" Flat Washer	-	16
18	P-14002-5	1/2" UNC Hex Nut	-	16
19	P-14713-4	1/4" BSPT - 8mm Elbow Fitting	0	3
20	A-15142-S	ELECTRIC CONTROLLER ASSEMBLY	-	1
21	P-15006	0.25inch BSPT 316 SS Check Valve	-	1
22	P-14727	0.25 inch BSPT Male Nipple	-	1
23	F111	Ø8mm FLEXIBLE TUBE	-	3000mm
24	15051	Product Label - Self Adhesive	-	1
25	15053	Safety Caution Label - Self Adhesive	-	4
26	15054	Filtaworx Trade Mark Label - Self Adhesive	-	2

NOTE:  
1. TYPICAL BOM ARRANGEMENT FOR ELECTRICAL CONTROLLER

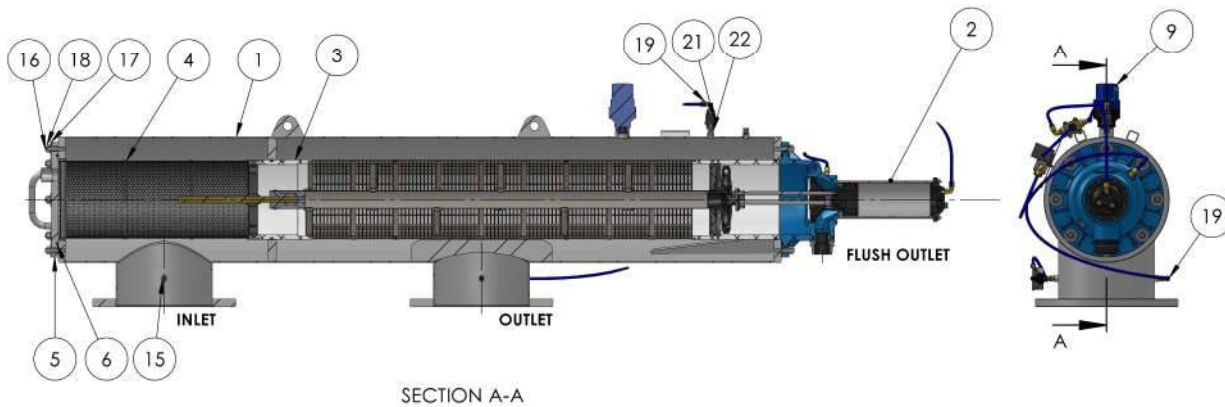
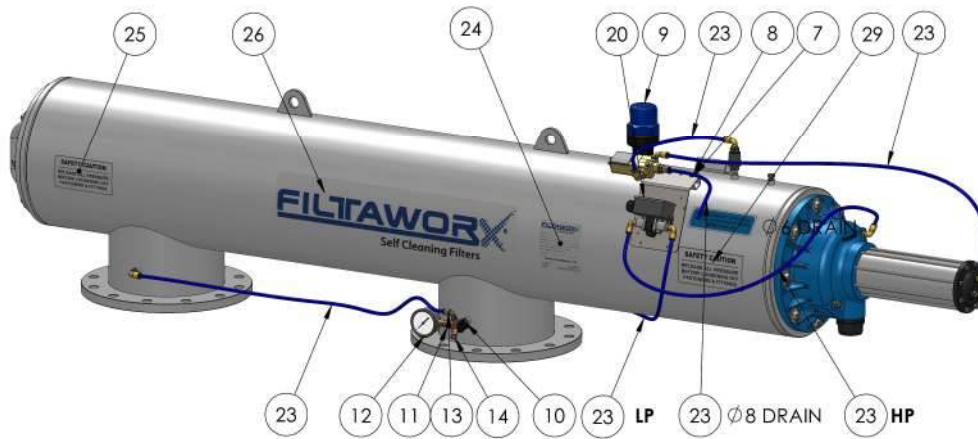


## PLC CONTROL

ITEM NO.	PartNo	Description	Revision	QTY.
1		BODY FABRICATION	6	1
2	A-21016-ES	End Cover	0	1
3		FINE SCREEN & DIRT	0	1
4		COARSE SCREEN	2	1
5		END COVER	0	1
6	P-11505	BS448 O-Ring	-	1
7	P-14017-1	M6 Spring Washer	-	2
8	P-14012-1	M6 x 10L Set Screw - Hex Head	-	2
9	P-15005	AIR RELEASE VALVE - 1" BSP	-	1
10	P-14711-4	1/4" BSPT to 1/8" BSPT MALE REDUCING NIPPLE	-	1
11	P-15032	3-WAY TAP -PRESSURE GAUGE	-	1
12	P-15001	1000 kpa Gauge-Liquid Filled	0	1
13	P-14730-4	1/8" BSPT - BMM ELBOW FITTINGS	-	1
14	P-14704-4	1/8" BSPT Plug	0	1

ITEM NO.	PartNo	Description	Revision	QTY.
15	P-14714-4	0.25 INCH BSPT PLUG -BRASS PLATED	0	2
16	P-14003-1	1/2"UNC x 55LG STUD BOLT	-	16
17	P-14001-1	1/2" Flat Washer	-	16
18	P-14002-5	1/2" UNC Hex Nut	-	16
19	P-14713-4	1/4" BSPT - 8mm Elbow Fitting	0	3
20	A-15136-S	PRESSURE SWITCH	0	1
21	P-15006	0.25inch BSPT 316 SS Check Valve	-	1
22	P-14727	0.25 inch BSPT Male Nipple	-	1
23	F111	Ø8mm FLEXIBLE TUBE	-	3000mm
24	15051	Product Label - Self Adhesive	-	1
25	15053	Safety Caution Label - Self Adhesive	-	4
26	15054	Filtaworx Trade Mark Label - Self Adhesive	-	2

NOTE  
1. TYPICAL BOM ARRANGEMENT FOR PLC CONTROLLER

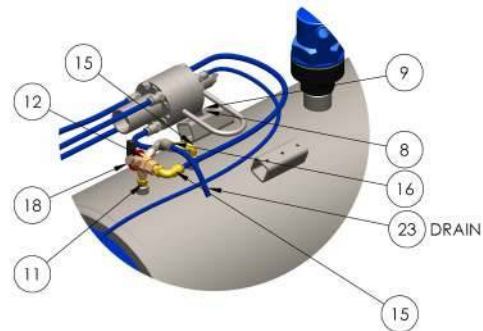
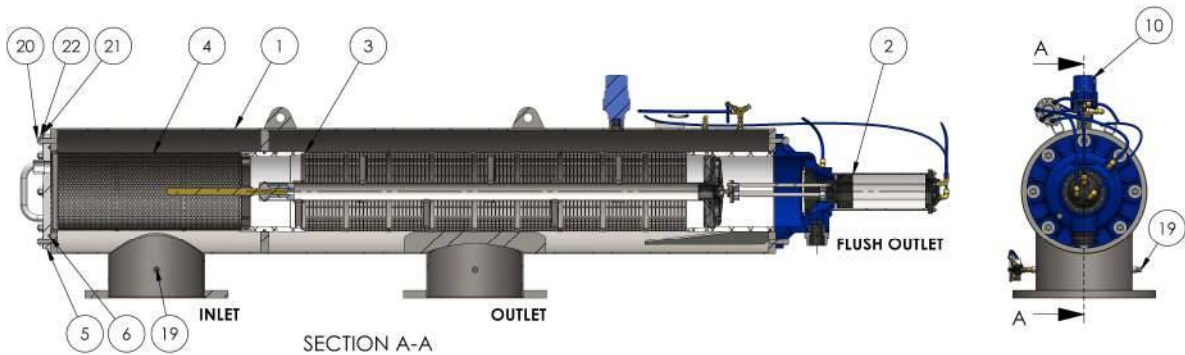


## HYDRAULIC CONTROL

ITEM NO.	PartNo	Description	Revision	QTY.
1		BODY FABRICATION	6	1
2	A-21016-H8	End Cover	0	1
3		FINE SCREEN & DIRT	0	1
4		COARSE SCREEN	2	1
5		END COVER	0	1
6	P-11505	B5448 O-Ring	-	1
7	P-15012	RINSE CONTROLLER	0	1
8	P-14017-1	M6 Spring Washer	-	1
9	P-14012-1	M6 x 10L Set Screw - Hex Head	-	1
10	P-15005	AIR RELEASE VALVE - 1" BSP	-	1
11	P-14711-4	1/4" BSPT to 1/8" BSPT MALE REDUCING NIPPLE	-	2
12	P-15031	3-way Tap for Pressure Gauge	-	1
13	P-15032	3-WAY TAP -PRESSURE GAUGE	-	1
14	P-15001	1000 kpa Gauge-Liquid Filled	0	1
15	P-14713-4	1/4" BSPT - 8mm Elbow Fitting	0	3

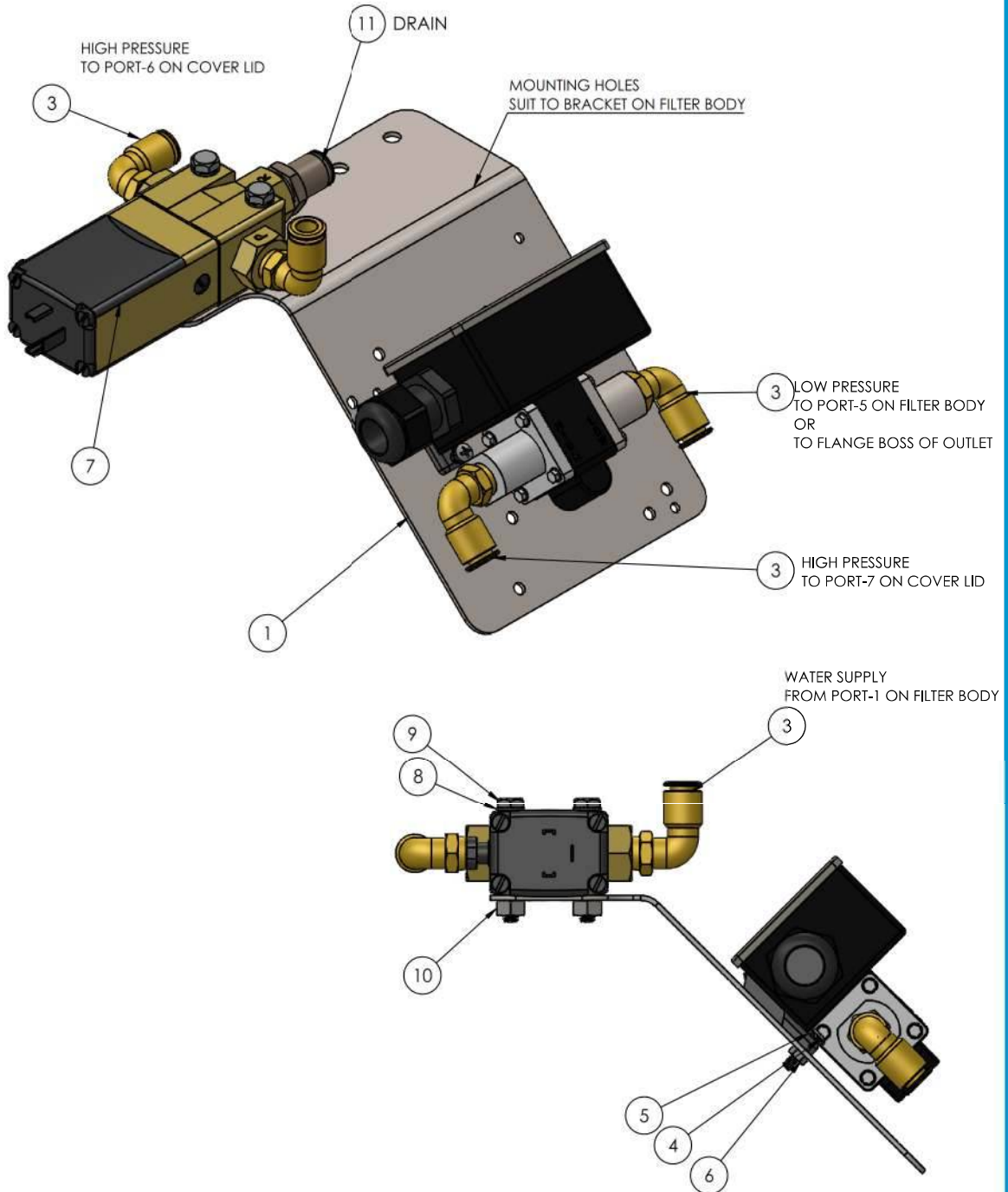
ITEM NO.	PartNo	Description	Revision	QTY.
16	P-14730-4	1/8" BSPT - 8MM ELBOW FITTINGS	-	2
17	P-14704-4	1/8" BSPT Plug	0	1
18	P-14704	1/8" BSPT Plug	0	1
19	P-14714-4	0.25 INCH BSPT PLUG -BRASS PLATED	0	2
20	P-14003-1	1/2"UNC x 55LG STUD BOLT	-	16
21	P-14001-1	1/2" Flat Washer	-	16
22	P-14002-5	1/2" UNC Hex Nut	-	16
23	F111	Ø8mm FLEXIBLE TUBE	-	5m
24	15051	PRODUCT LABEL-SELF ADHESIVE	0	1
25	15052	VALVE LABEL-SELF ADHESIVE	0	1
26	15053	SAFETY CAUTION LABEL - SELF ADHESIVE	0	2
27	15054	FILTAWORX REGISTERED TRADEMARK SELF ADHESIVE	0	1

**NOTE**  
1. TYPICAL BOM ARRANGEMENT FOR HYDRAULIC CONTROLLER

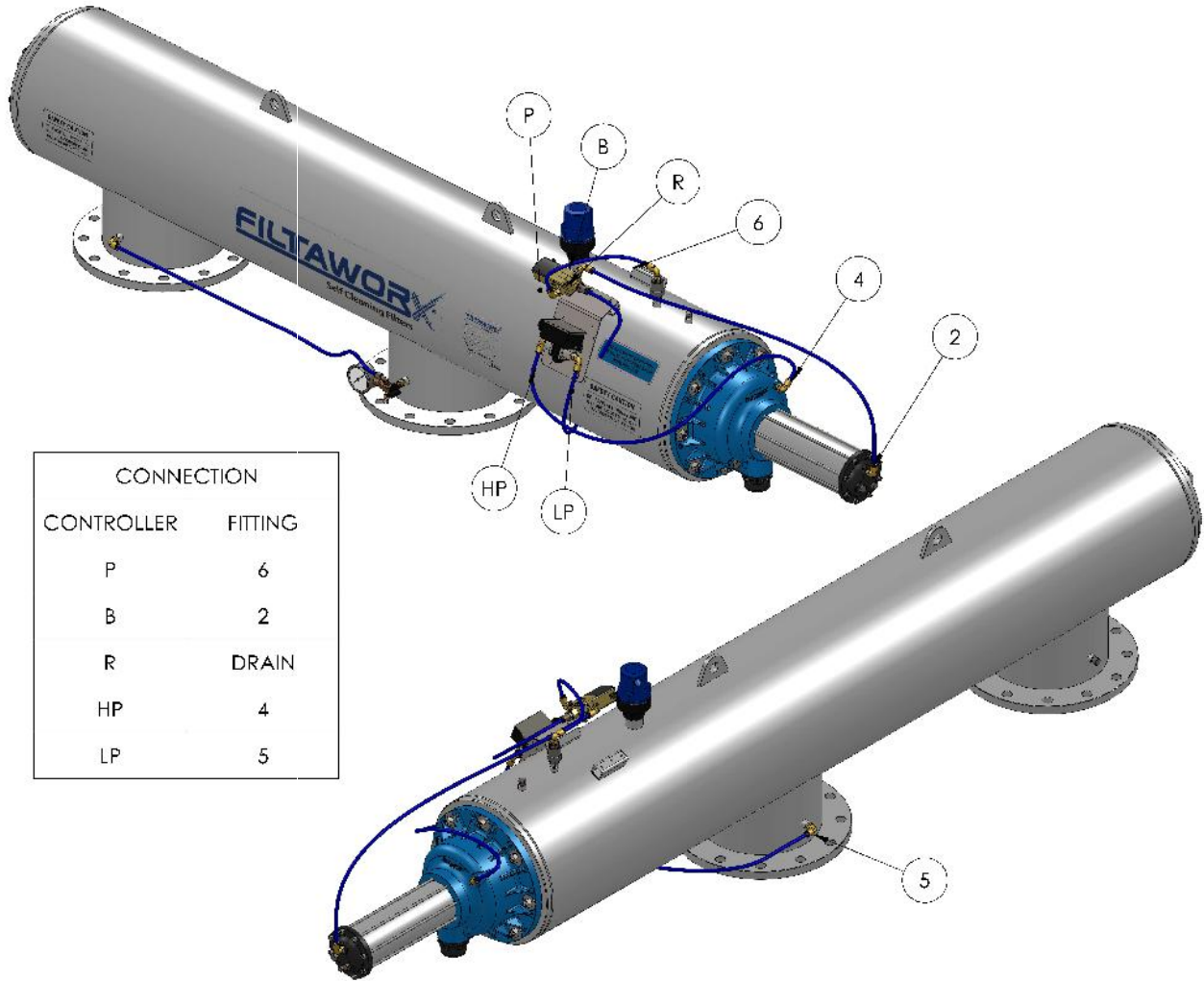


# PLC Controller : A-15114

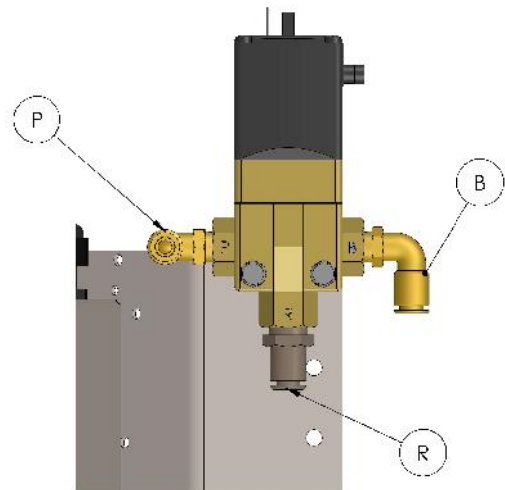
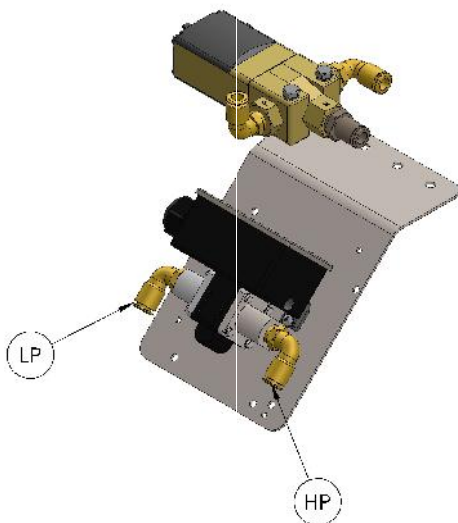
ITEM NO.	PartNo	Description	QTY.
1	P-15103	MOUNTING BRACKET	1
2	P-15139	Differential Pressure Switch	1
3	P-14713-4	1/4" BSPT - 8mm Elbow Fitting	4
4	P-14058-1	M4x1.6L Set Screw	3
5	P-14059-1	M4 Flat Washer	3
6	P-14060-1	M4 Hex. Nut	3
7	P-15104-D	8mm solenoid	1
8	P-14017-1	M6 Spring Washer	2
9	P-14072-1	M6x1 - 45 Length - Hexhead	2
10	P-14019-1	M6x1 Hex Nut	2
11	P-14724-4	1/8" BSPT - 8mm Straight Fitting	1



## PLC Controller : Plumbing Connection

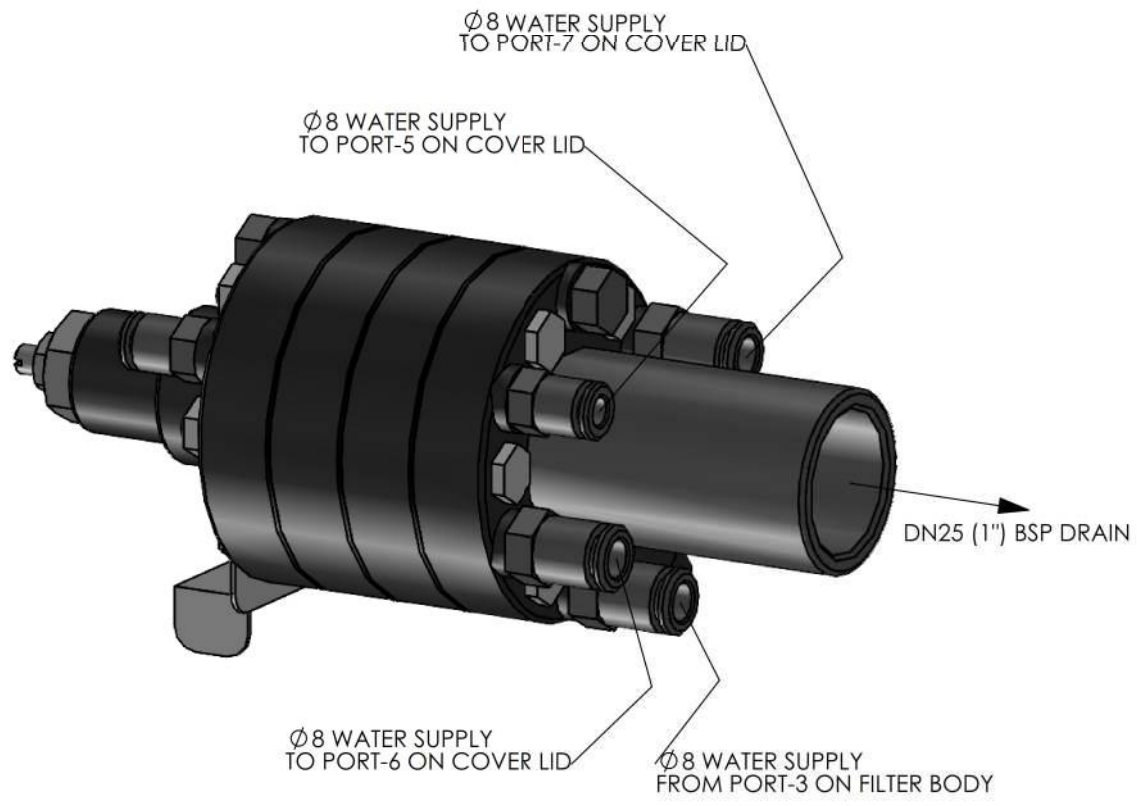
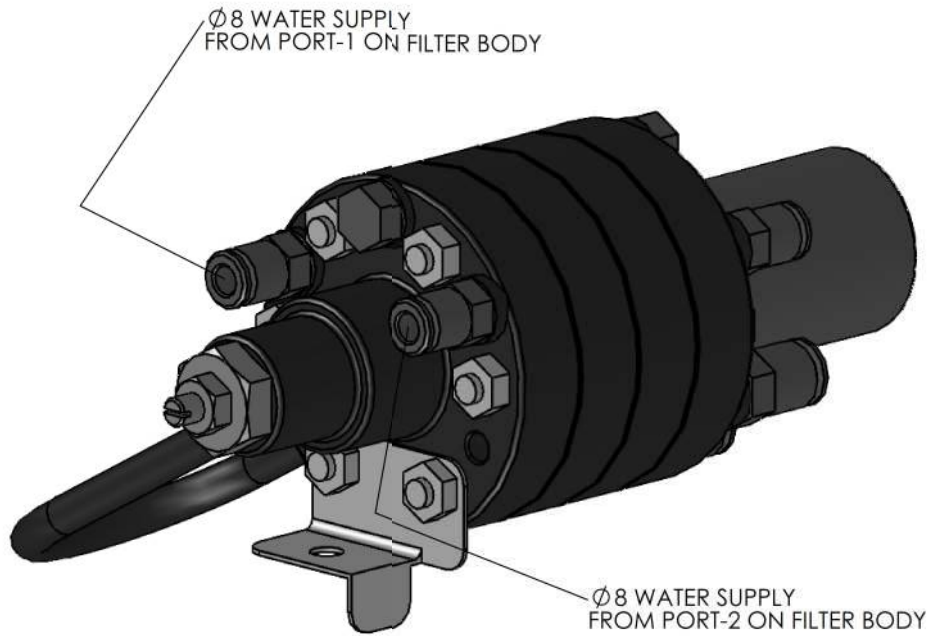


CONNECTION	
CONTROLLER	FITTING
P	6
B	2
R	DRAIN
HP	4
LP	5

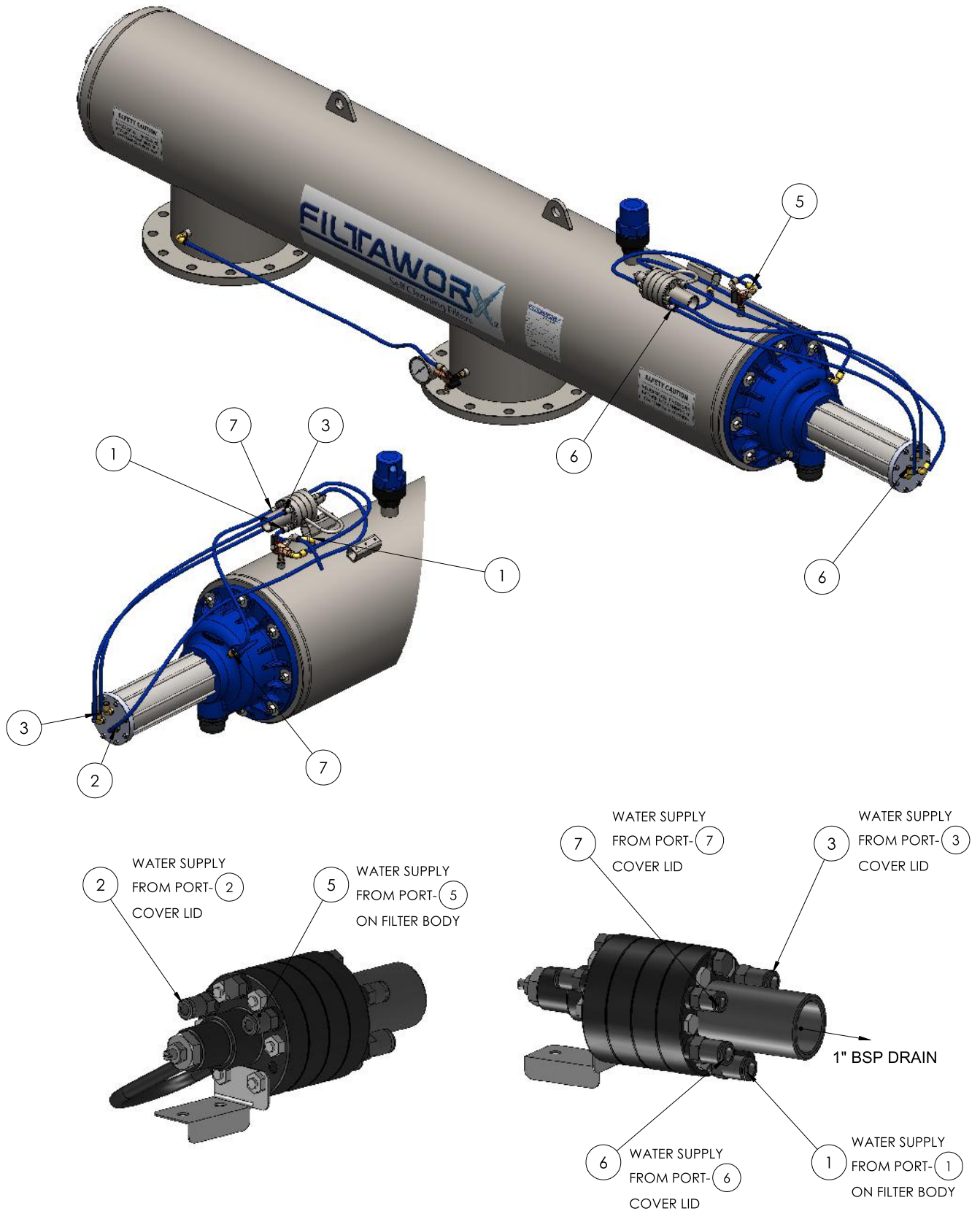


**PLC CONTROLLER CONNECTION**

# Hydraulic Controller : A-15012



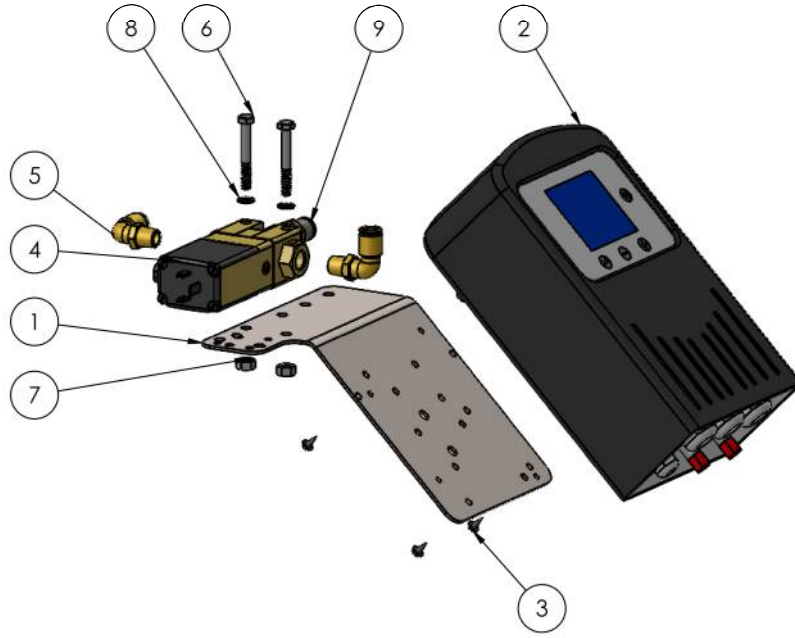
# Hydraulic Controller : Plumbing Connections



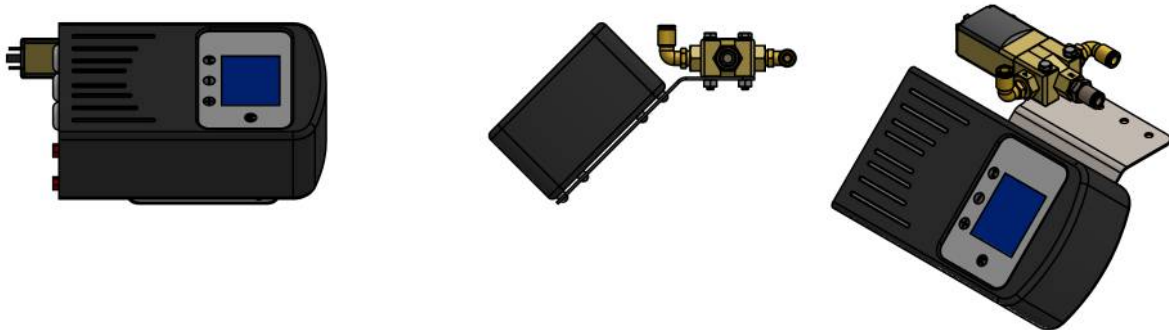
**HYDRAULIC CONTROL CONNECTION**

# Electric Controller : A-15142

ITEM NO.	PartNo	Description	QTY.
1	P-15103	MOUNTING BRACKET	1
2	P-15131	Filtron 1-10	1
3	P-14005	8G x 3/8" L SELF TAPPING SCREW -PAN HEAD	4
4	P-15104-D	8mm solenoid	1
5	P-14713-4	1/4" BSPT - 8mm Elbow Fitting	2
6	P-14072-1	M6x1 - 45 Length - Flexhead	2
7	P-14019-1	M6x1 Hex Nut	2
8	P-14017-1	M6 Spring Washer	2
9	P-14724-4	1/8" BSPT - 8mm Straight Fitting	1



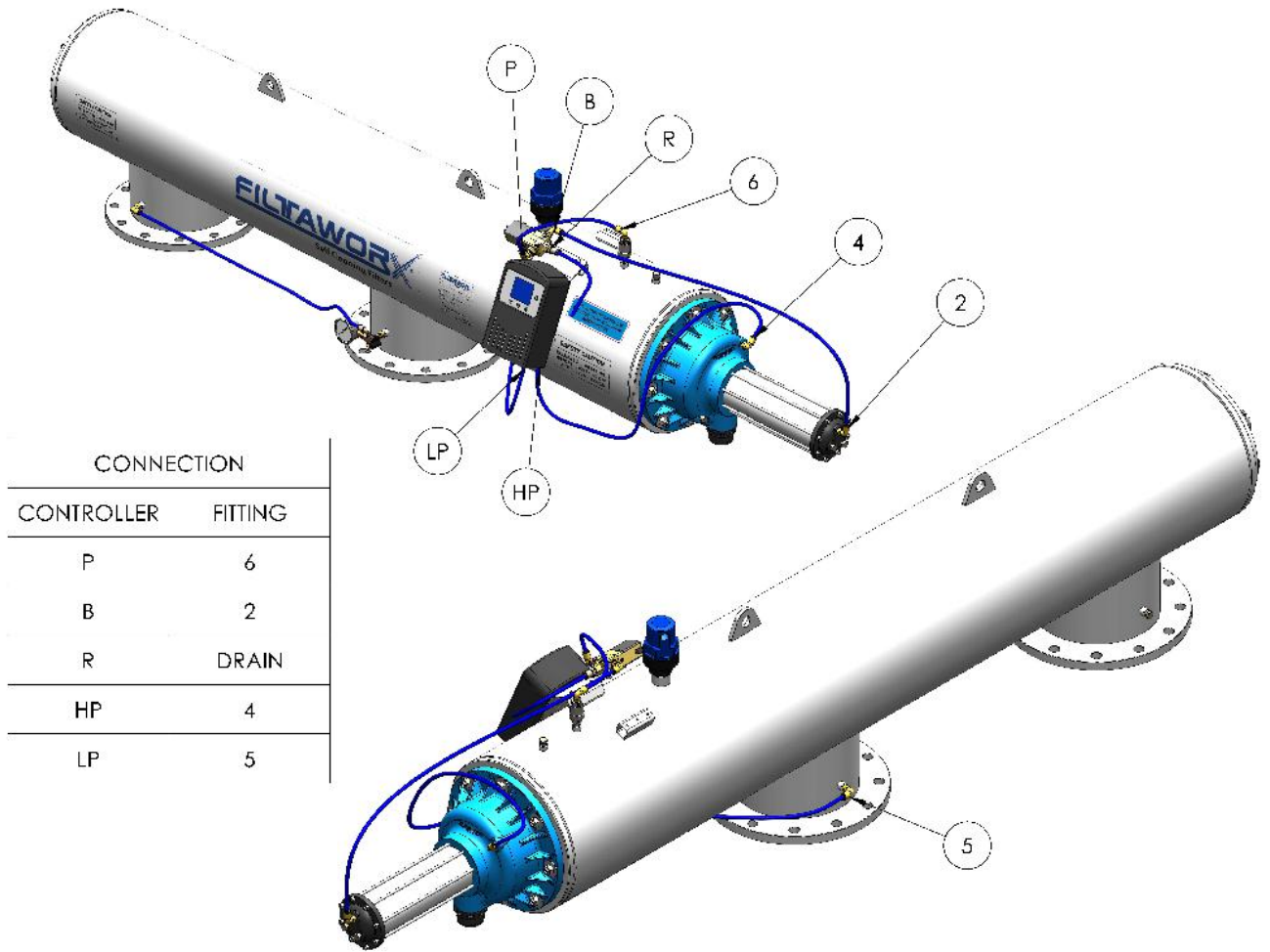
## TO PERPENDICULAR MOUNTING FOR W050 ~ FW100 FILTERS



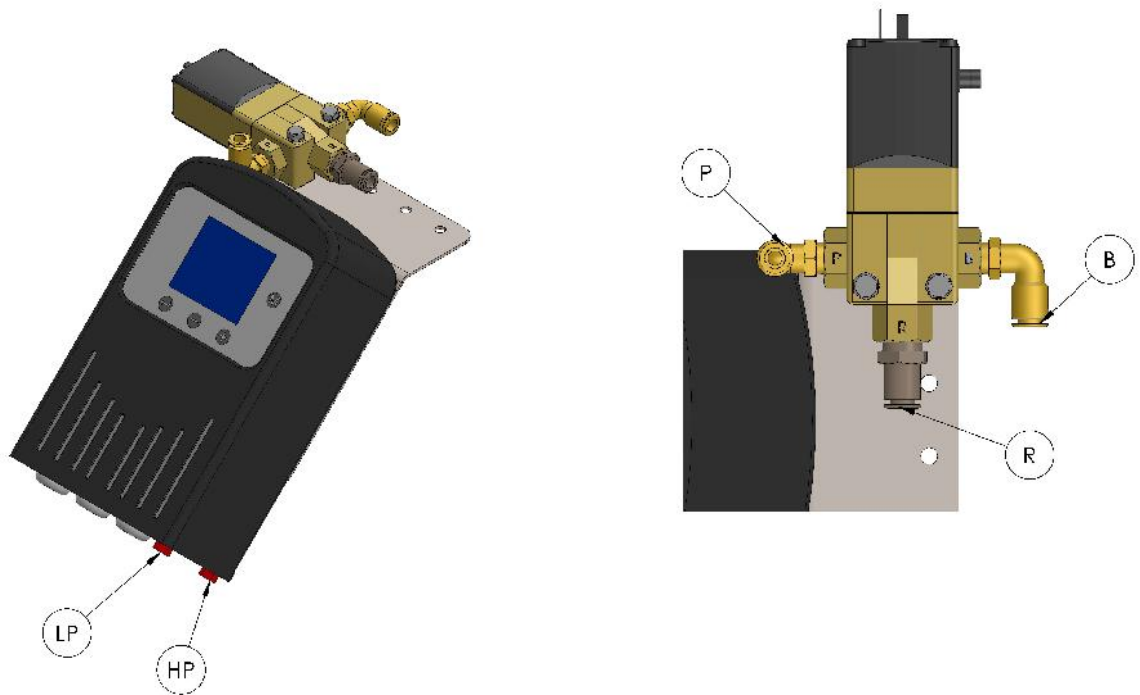
## PARALLEL MOUNTING FOR W100EX ~ FW450 FILTERS



## Electric Controller : Plumbing Connections



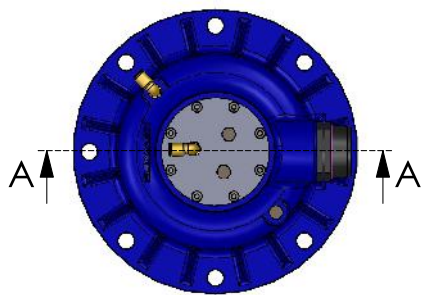
CONNECTION	
CONTROLLER	FITTING
P	6
B	2
R	DRAIN
HP	4
LP	5



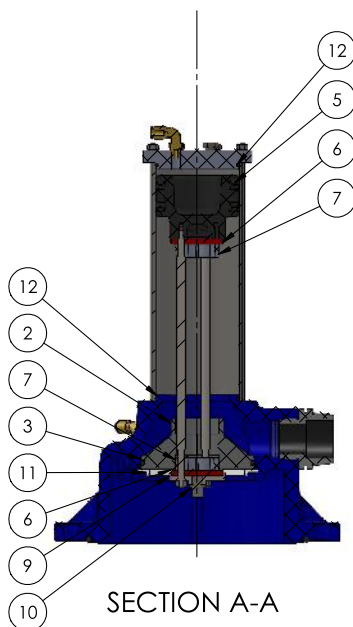
**ELECTRIC CONTROL CONNECTION STANDARD**

# CoverLid : A-21016

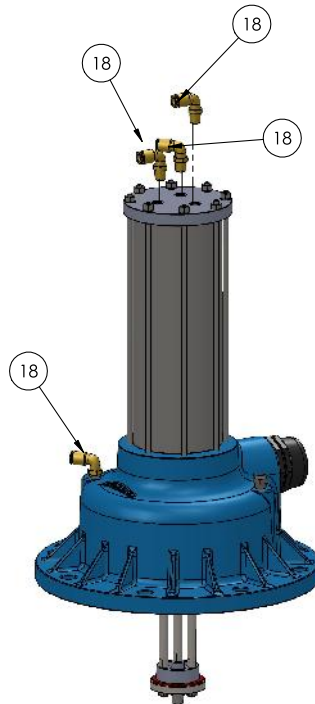
ITEM NO.	PART NO.	DESCRIPTION	REVISION	QTY.
1	P-16002	Cover Lid	10	1
2	P-21014	EXHAUST VALVE SEAT	1	1
3	P-11503	BS 351 O-RING	0	1
4	P-21017	PISTON PLUG	1	1
5	P-21001	U-Ring Seal	5	2
6	P-21007	Seal Washer	2	2
7	P-21008	DISK SEAT	0	2
8	P-21009	Piston Support	1	3
9	P-21005	Male Bearing Sub-Assembly	1	1
10	P-21006	MALE BEARING	1	1
11	P-13001	LOCKING RING	3	1
12	P-11502	BS237 O-RING	0	2
13	P-21013	Cylinder Support Rod	0	8
14	P-21010	Cylinder Sleeve	1	1
15	P-21012	CYLINDER END PLATE	0	1
16	P-14016	M6 Flat Washer - 304 S.S	0	8
17	P-14019	M6X1 HEX NUT - NYLOC	0	8
18	P-14713-4	1/4" BSPT - 8mm Elbow Fitting	0	2
19	P-14714-4	0.25 INCH BSPT PLUG -BRASS PLATED	0	3
20	P-13003	2" BSPT TO 1.5" BSPT HEX REDUCING NIPPLE	0	1
21	P-11505	BS448 O-Ring	-	1
22	P-14018	M6X1 HEX NUT NYLOC	0	3



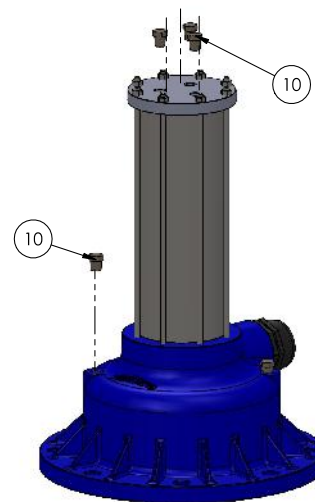
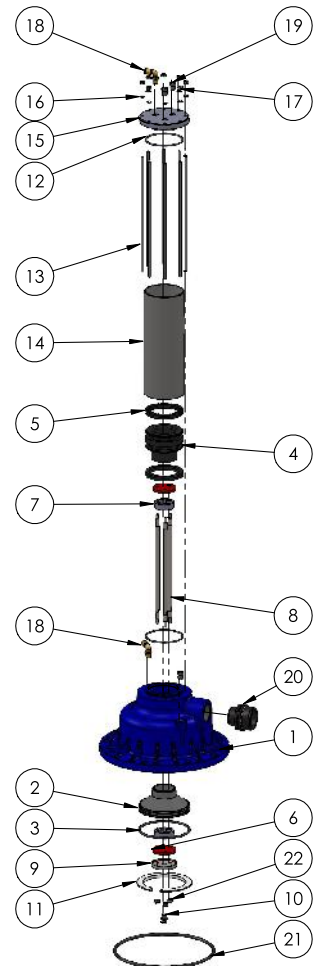
STROKE POSITION



FOR ELECTRIC AND PLC CONTROLLER



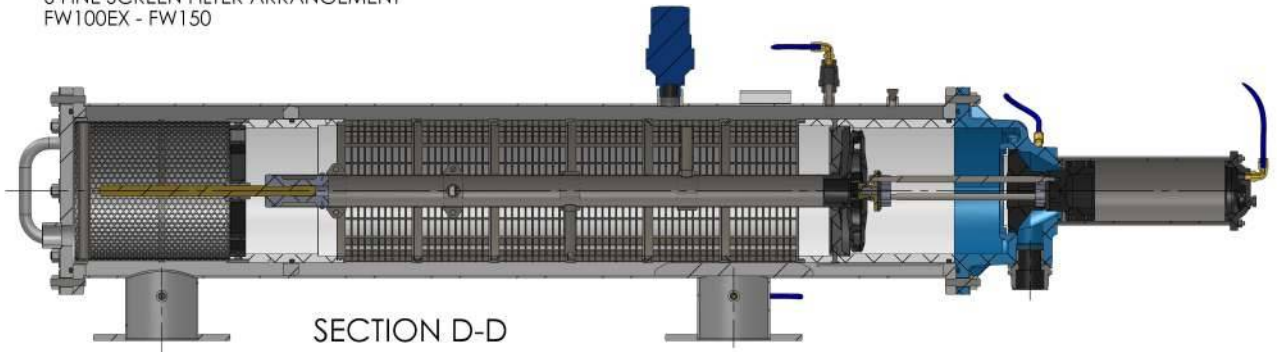
FOR HYDRAULIC CONTROLLER



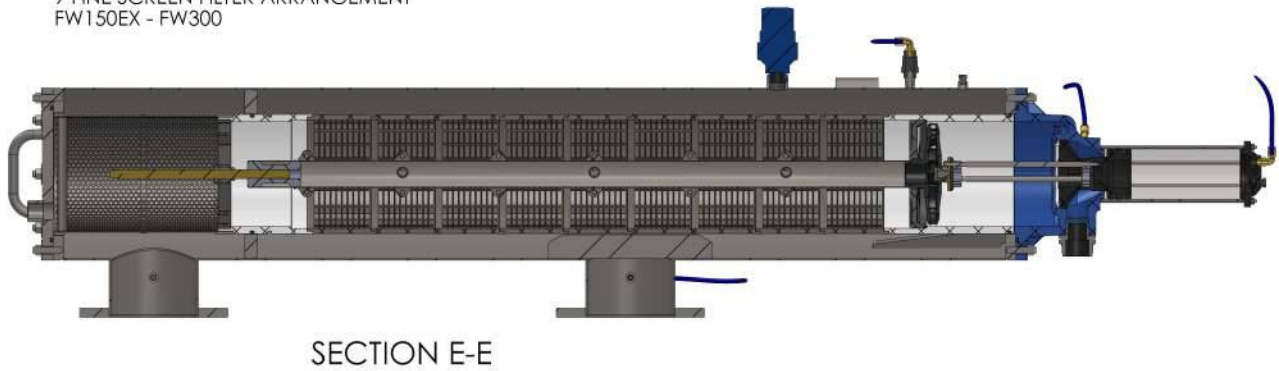
FOR NO CONTROLLER

## Filter Screen Configuration

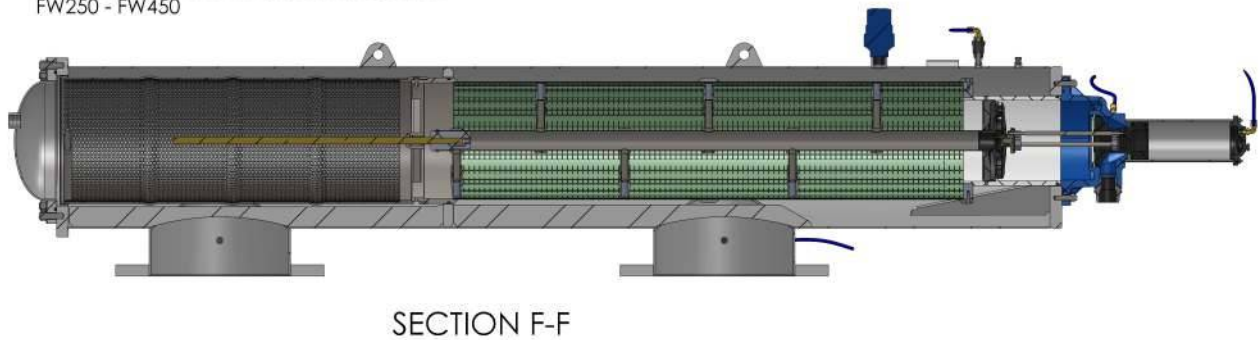
6 FINE SCREEN FILTER ARRANGEMENT  
FW100EX - FW150



9 FINE SCREEN FILTER ARRANGEMENT  
FW150EX - FW300



FINE FILTER WITH ADAPTOR ARRANGEMENT  
FW250 - FW450

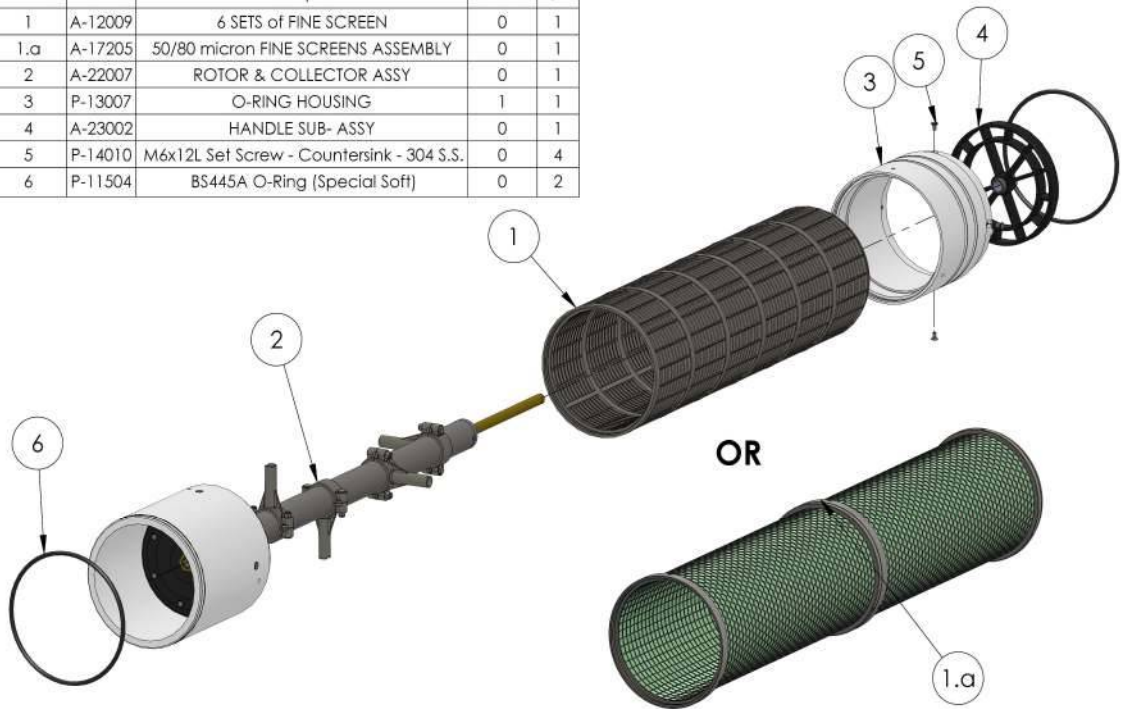


# Fine Screen and Drit Collector

## FW100EX - FW150

A-23001 or A-23024

ITEM NO.	PartNo	Description	Revision	QTY.
1	A-12009	6 SETS of FINE SCREEN	0	1
1.a	A-17205	50/80 micron FINE SCREENS ASSEMBLY	0	1
2	A-22007	ROTOR & COLLECTOR ASSY	0	1
3	P-13007	O-RING HOUSING	1	1
4	A-23002	HANDLE SUB- ASSY	0	1
5	P-14010	M6x12L Set Screw - Countersink - 304 S.S.	0	4
6	P-11504	BS445A O-Ring (Special Soft)	0	2



6 SET OF FINE SCREEN

ITEM NO.	PartNo	Description	QTY.
1.1	P-12002	FINE SCREEN	6

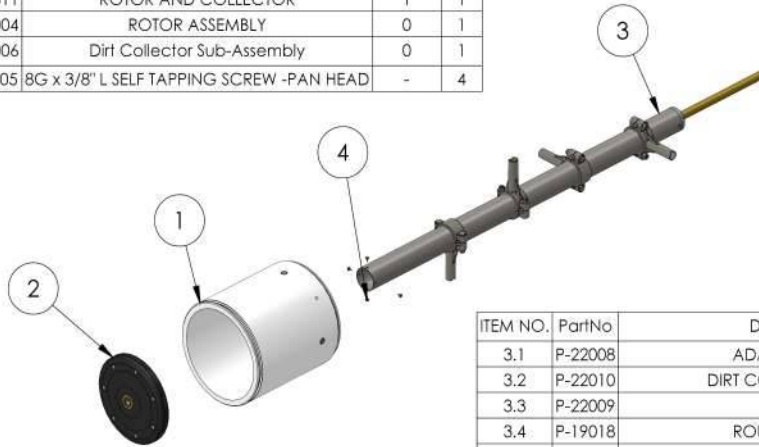


HANDLE SUB-ASSY

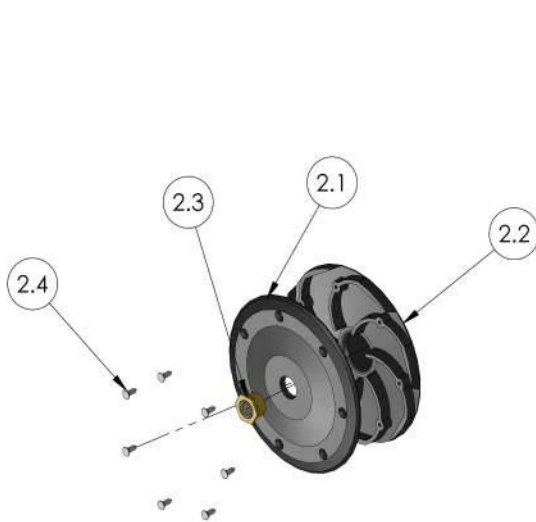
ITEM NO.	PartNo	Description	QTY.
4.1	P-12011	SCREEN HANDLE	1
4.2	P-14004	1" - 12 UNF BUSH	1

## Dirt Collector Sub-Assy : 6 Screen Configuration A-22007

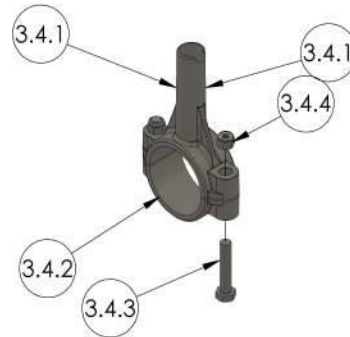
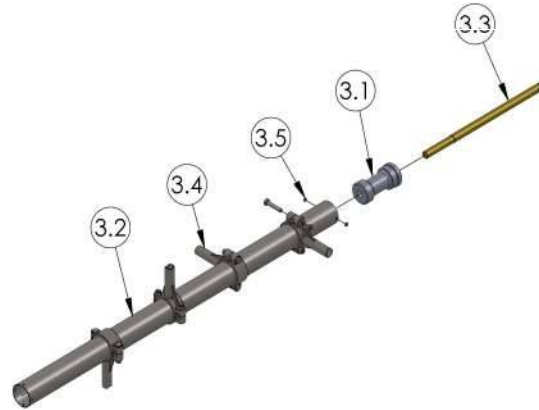
ITEM NO.	PartNo	Description	Revision	QTY.
1	A-22011	ROTOR AND COLLECTOR	1	1
2	A-22004	ROTOR ASSEMBLY	0	1
3	A-22006	Dirt Collector Sub-Assembly	0	1
4	P-14005	8G x 3/8" L SELF TAPPING SCREW -PAN HEAD	-	4



ITEM NO.	PartNo	Description	QTY.
3.1	P-22008	ADAPTER SHAFT	1
3.2	P-22010	DIRT COLLECTOR TUBE	1
3.3	P-22009	SHAFT	1
3.4	P-19018	ROUND NOZZLE	4
3.5	P-14005	8G x 3/8" L SELF TAPPING SCREW -PAN HEAD	4



ITEM NO.	PartNo	Description	QTY.
2.1	P-19001	ROTOR COVER	1
2.2	P-19002	ROTOR	1
2.3	P-22001	FEMALE BEARING HOLDER	1
2.4	P-14020	G10x0.75 X16MM LG	7

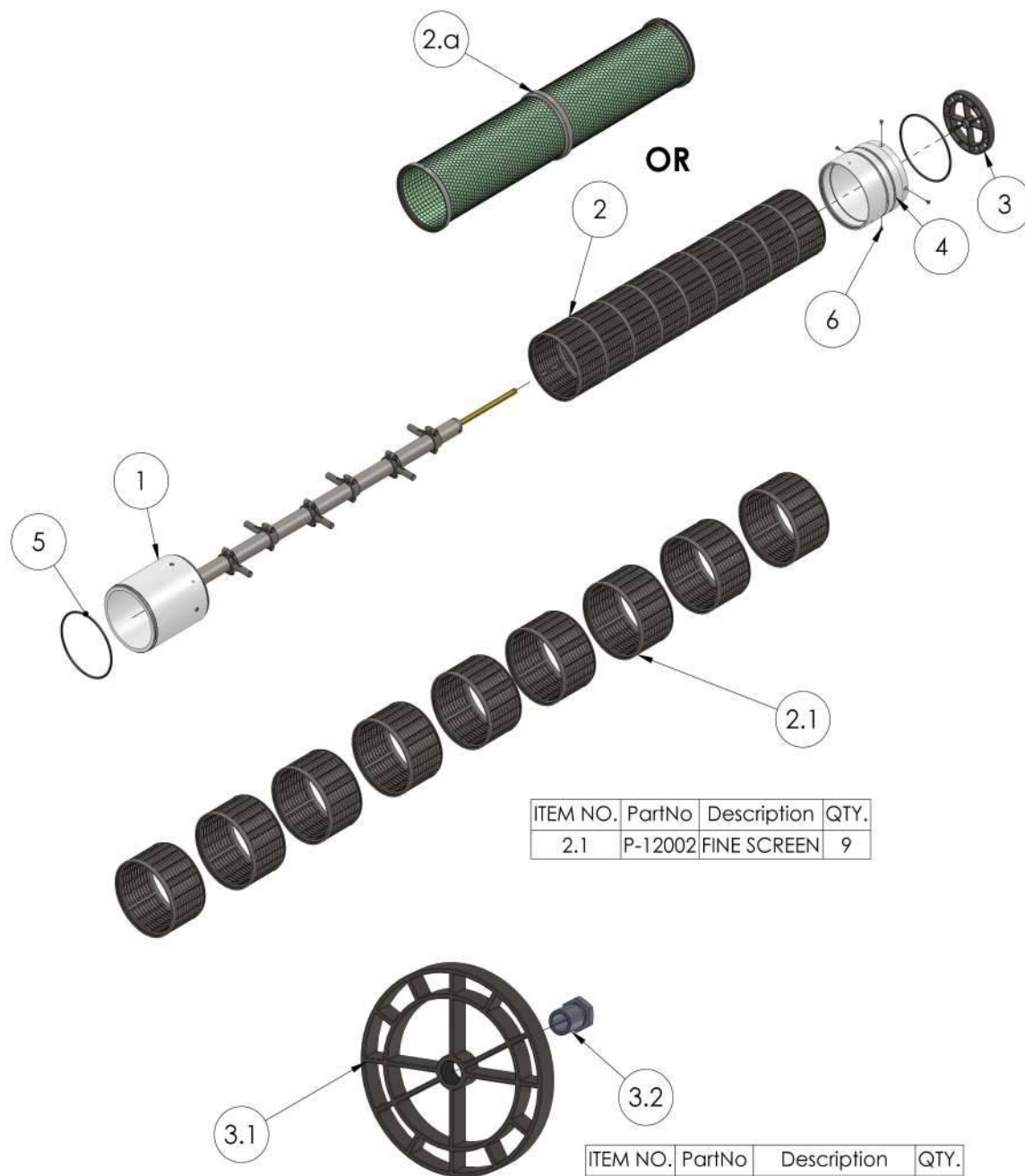


ITEM NO.	PartNo	Description	QTY.
3.4.1	P-19017	NOZZLE WITH CLAMP	1
3.4.2	P-19012	NOZZLE - CLAMP	1
3.4.3	P-14033	M8X1.25 HEX BOLT 40MM LG	2
3.4.4	P-14032	M8X1.25 HEX NYLOC NUT	2

## W150EX - FW250

A-23003 or A-23025

ITEM NO.	PART NO.	DESCRIPTION	REVISION	QTY.
1	A-22012	ROTOR COLLECTOR	1	1
2	A-12010	FINE SCREEN SUB-ASSY	0	1
2.a	A-17206	50/80 micron FINE SCREENS	0	1
3	A-23002	HANDLE SUB- ASSY	0	1
4	P-13007	O-RING HOUSING	1	1
5	P-11504	BS445A O-Ring (Special Soft)	0	2
6	P-14010	M6x12L Set Screw - Countersink - 304 S.S.	0	4

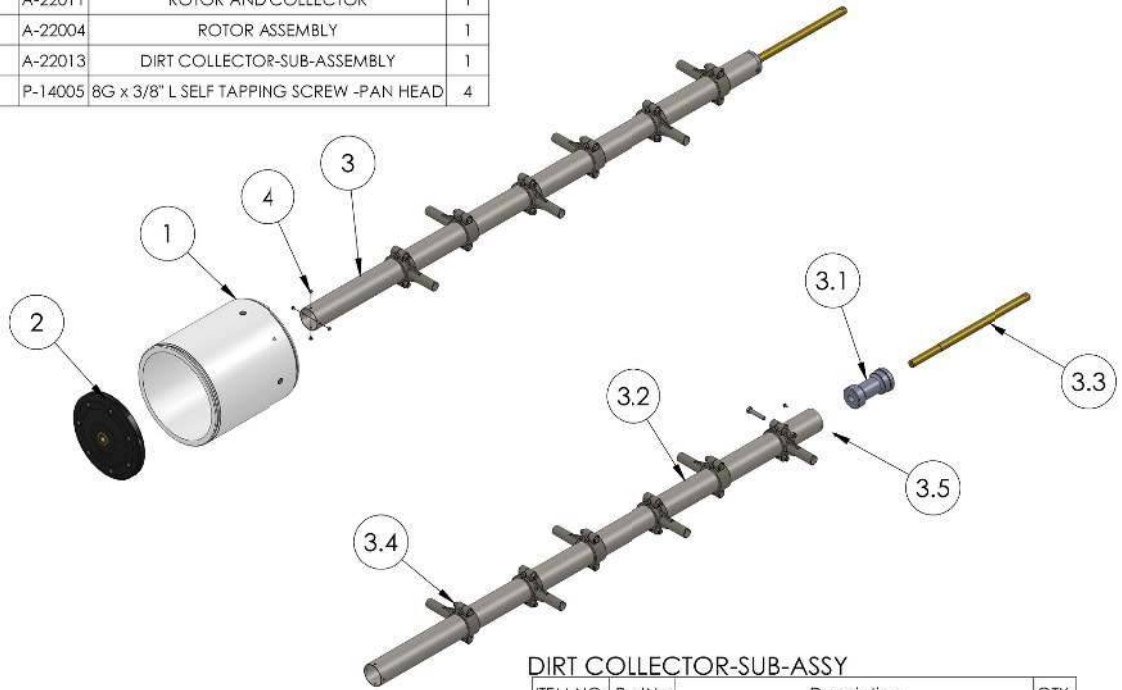


ITEM NO.	PartNo	Description	QTY.
2.1	P-12002	FINE SCREEN	9

ITEM NO.	PartNo	Description	QTY.
3.1	P-12011	SCREEN HANDLE	1
3.2	P-14004	1" - 12 UNF BUSH	1

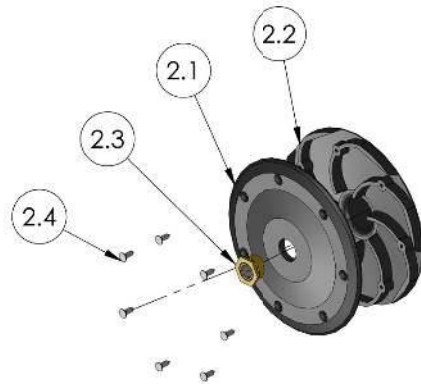
## Dirt Collector Sub-Assy : 9 Screen Configuration

ITEM NO.	PartNo	Description	QTY.
1	A-22011	ROTOR AND COLLECTOR	1
2	A-22004	ROTOR ASSEMBLY	1
3	A-22013	DIRT COLLECTOR-SUB-ASSEMBLY	1
4	P-14005	8G x 3/8" L SELF TAPPING SCREW -PAN HEAD	4



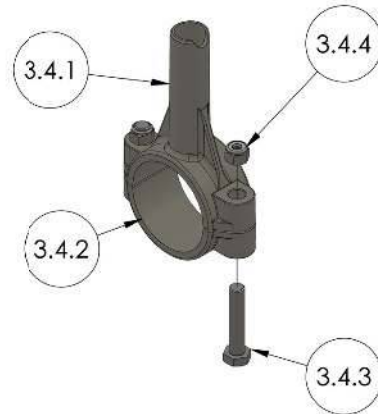
### DIRT COLLECTOR-SUB-ASSY

ITEM NO.	PartNo	Description	QTY.
3.1	P-22008	ADAPTER SHAFT	1
3.2	P-22014	DIRT COLLECTOR TUBE	1
3.3	P-22009	SHAFT	1
3.4	P-19018	ROUND NOZZLE	6
3.5	P-14005	8G x 3/8" L SELF TAPPING SCREW -PAN HEAD	4



### ROTOR ASSEMBLY

ITEM NO.	PartNo	Description	QTY.
2.1	P-19001	ROTOR COVER	1
2.2	P-19002	ROTOR	1
2.3	P-22001	FEMALE BEARING HOLDER	1
2.4	P-14020	G10x0.75 X16MM LG	7



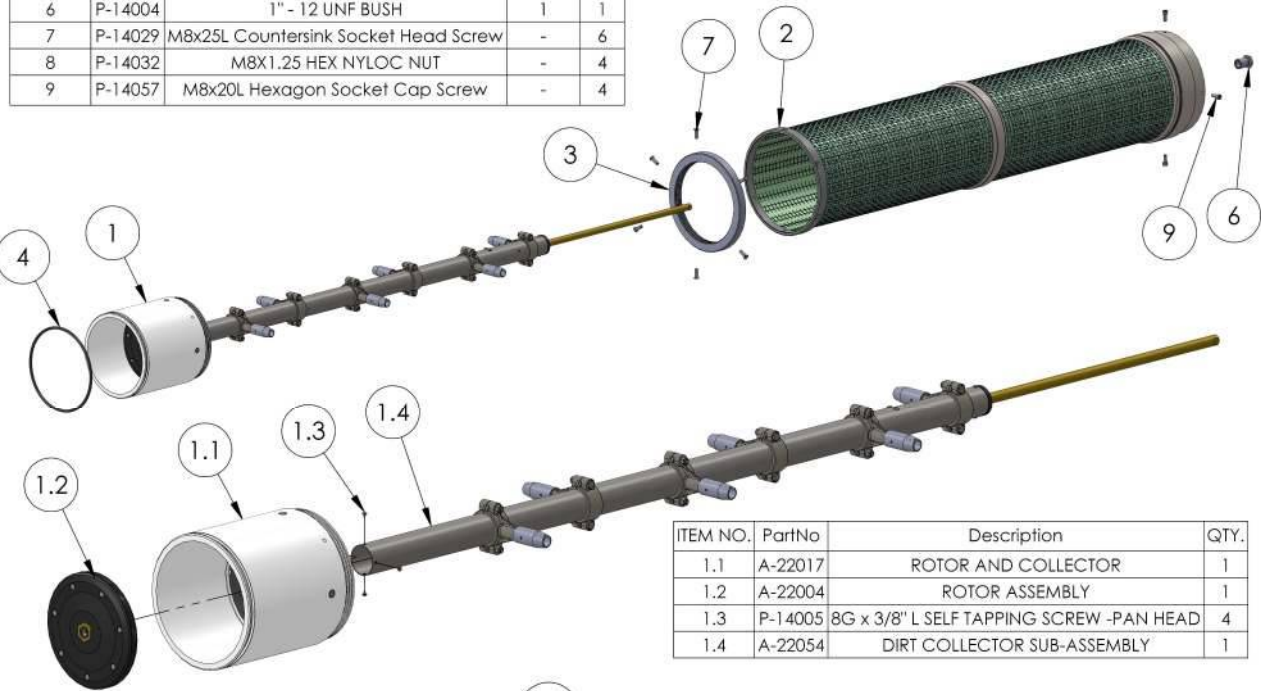
### ROUND NOZZLE

ITEM NO.	PartNo	Description	QTY.
3.4.1	P-19017	NOZZLE WITH CLAMP	1
3.4.2	P-19012	NOZZLE - CLAMP	1
3.4.3	P-14033	M8X1.25 HEX BOLT 40MM LG	2
3.4.4	P-14032	M8X1.25 HEX NYLOC NUT	2

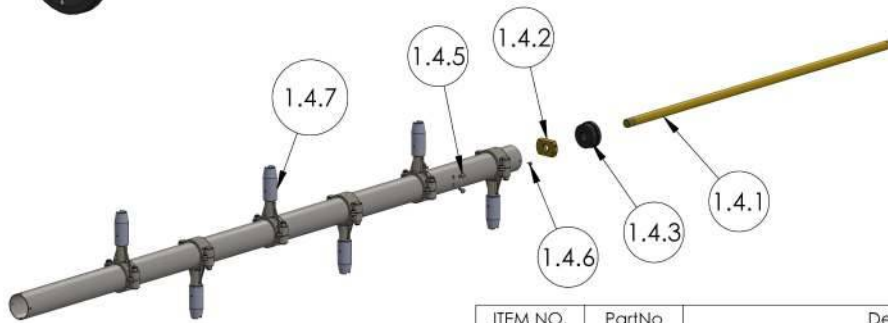
# W250EX-FW300

A-23004

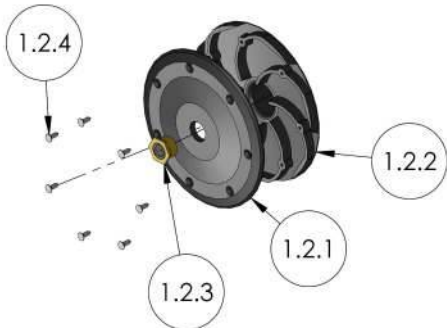
ITEM NO.	PartNo	Description	Revision	QTY.
1	A-22015	ROTOR & COLLECTOR	0	1
2	A-17207	FINE SCREEN	4	1
3	P-13008	ADAPTOR RING	2	1
4	P-11504	BS445A O-Ring (Special Soft)	0	1
5	P-11511	O-Ring - BS450	-	1
6	P-14004	1" - 12 UNF BUSH	1	1
7	P-14029	M8x25L Countersink Socket Head Screw	-	6
8	P-14032	M8X1.25 HEX NYLOC NUT	-	4
9	P-14057	M8x20L Hexagon Socket Cap Screw	-	4



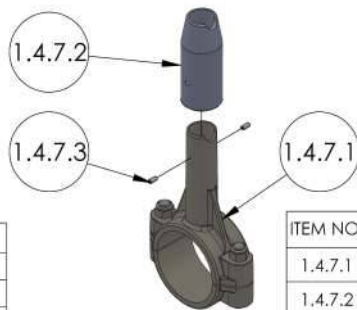
ITEM NO.	PartNo	Description	QTY.
1.1	A-22017	ROTOR AND COLLECTOR	1
1.2	A-22004	ROTOR ASSEMBLY	1
1.3	P-14005	8G x 3/8" L SELF TAPPING SCREW -PAN HEAD	4
1.4	A-22054	DIRT COLLECTOR SUB-ASSEMBLY	1



ITEM NO.	PartNo	Description	QTY.
1.4.1	P-22052	Dirt Collector Shaft - fits to Shaft Retainer	1
1.4.2	P-22050	Dirt Collector Shaft Retainer	1
1.4.3	P-22051	Dirt Collector Shaft Support	1
1.4.4	P-22053	DIRT COLLECTOR TUBE	1
1.4.5	P-14071	M5 x 3/8" Length - Button Head Socket Screw	4
1.4.6	P-14005	8G x 3/8" L SELF TAPPING SCREW -PAN HEAD	2
1.4.7	A-22019	Nozzle Assembly with Extensions - for FW250EX-FW300	6



ITEM NO.	PartNo	Description	QTY.
1.2.1	P-19001	ROTOR COVER	1
1.2.2	P-19002	ROTOR	1
1.2.3	P-22001	FEMALE BEARING HOLDER	1
1.2.4	P-14020	G10x0.75 X16MM LG	7

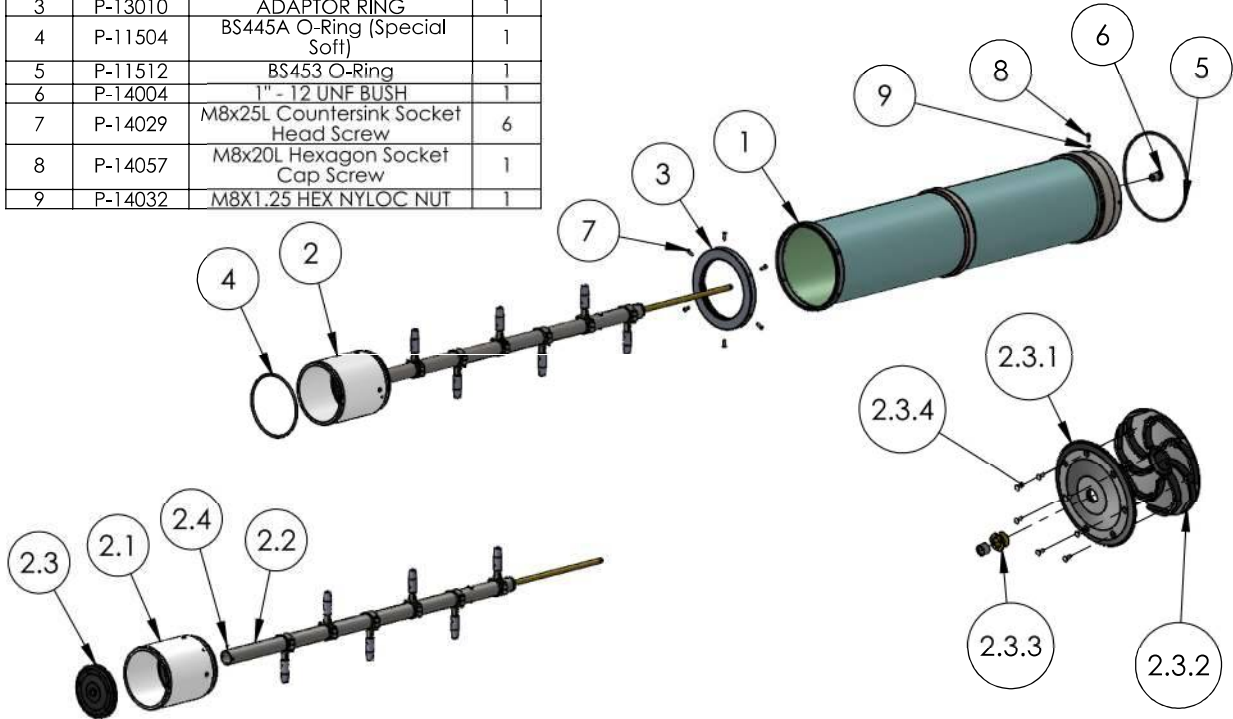


ITEM NO.	PartNo	Description	QTY.
1.4.7.1	P-19018	ROUND NOZZLE	1
1.4.7.2	P-22020	NOZZLE EXTENTION	1
1.4.7.3	P-14101	Dia.0.128 inch - 0.24 inch Length - Rolled Spring Pin	2

## FW350 - FW400

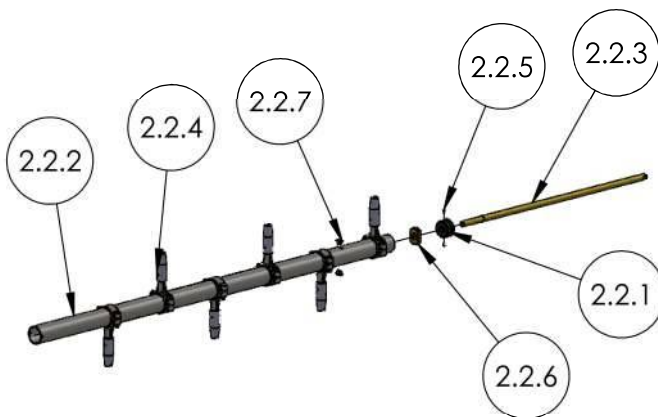
A-23005

ITEM NO.	PartNo	Description	QTY.
1	A-17208	FINE SCREEN	1
2	A-22022	ROTOR & COLLECTOR	1
3	P-13010	ADAPTOR RING	1
4	P-11504	BS445A O-Ring (Special Soft)	1
5	P-11512	BS453 O-Ring	1
6	P-14004	1" - 12 UNF BUSH	1
7	P-14029	M8x25L Countersink Socket Head Screw	6
8	P-14057	M8x20L Hexagon Socket Cap Screw	1
9	P-14032	M8X1.25 HEX NYLOC NUT	1

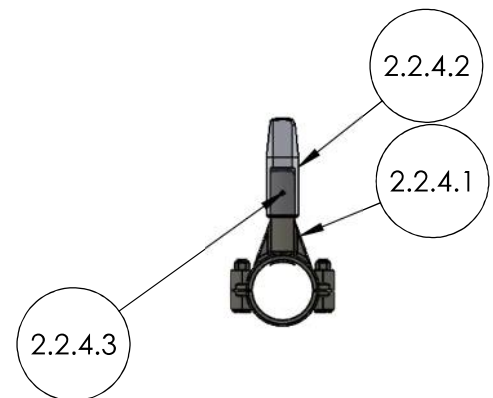


ITEM NO.	PartNo	Description	QTY.
2.1	A-22017	ROTOR AND COLLECTOR	1
2.2	A-22023	Dirt Collector Sub-Assembly	1
2.3	A-22004	ROTOR ASSEMBLY	1
2.4	P-14005	8G x 3/8" L SELF TAPPING SCREW -PAN HEAD	4

ITEM NO.	PartNo	Description	Q
2.3.1	P-19001	ROTOR COVER	
2.3.2	P-19002	ROTOR	
2.3.3	P-22001	FEMALE BEARING HOLDER	
2.3.4	P-14020	G10x0.75 X16MM LG	



ITEM NO.	PartNo	Description	QTY.
2.2.1	P-22051	Dirt Collector Shaft Support	1
2.2.2	P-22018	Collector Tube	1
2.2.3	P-22026	SHAFT	1
2.2.4	A-22024	Nozzle Assembly with Extensions - for FW350-FW400	6
2.2.5	P-14005	8G x 3/8" L SELF TAPPING SCREW -PAN HEAD	2
2.2.6	P-22050	Dirt Collector Shaft Retainer	1
2.2.7	P-14071	M5 x 3/8" Length - Button Head Socket Screw	4

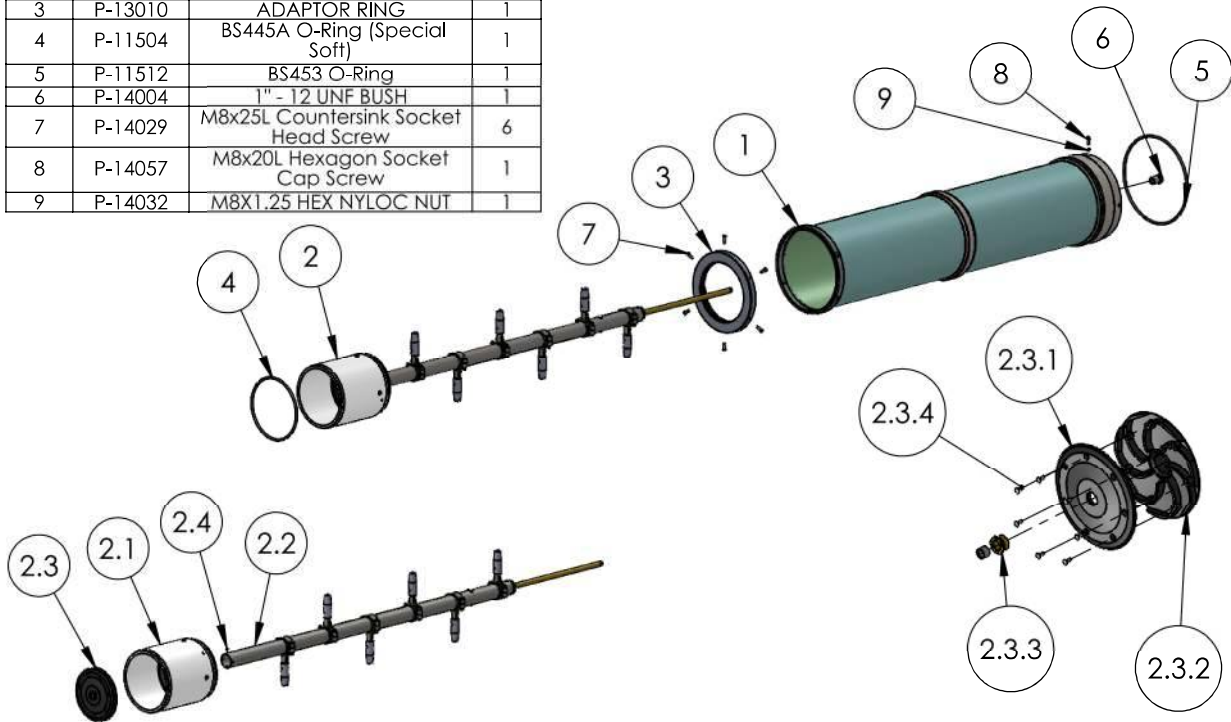


ITEM NO.	PartNo	Description	
2.2.4.1	A-19018	ROUND NOZZLE	
2.2.4.2	P-22025	NOZZLE EXTENSION	
2.2.4.3	P-14101	Rolled Spring Pin	

# FW450

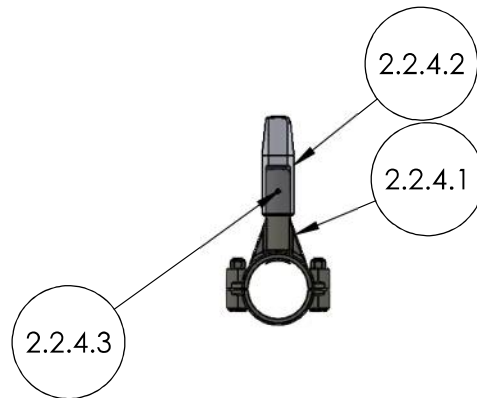
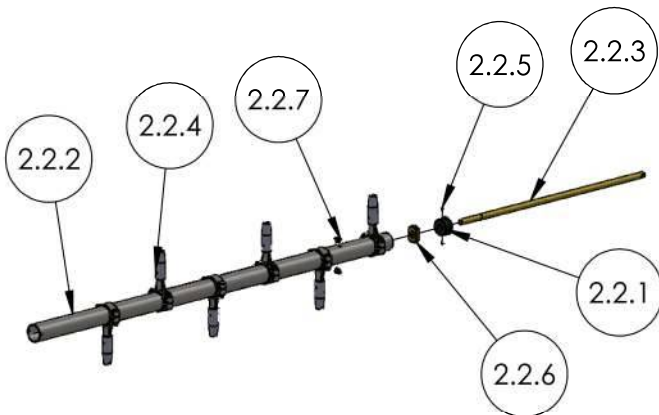
A-23028

ITEM NO.	PartNo	Description	QTY.
1	A-17208	FINE SCREEN	1
2	A-22022	ROTOR & COLLECTOR	1
3	P-13010	ADAPTOR RING	1
4	P-11504	BS445A O-Ring (Special Soft)	1
5	P-11512	BS453 O-Ring	1
6	P-14004	1" - 12 UNF BUSH	1
7	P-14029	M8x25L Countersink Socket Head Screw	6
8	P-14057	M8x20L Hexagon Socket Cap Screw	1
9	P-14032	M8X1.25 HEX NYLOC NUT	1



ITEM NO.	PartNo	Description	QTY.
2.1	A-22017	ROTOR AND COLLECTOR	1
2.2	A-22023	Dirt Collector Sub-Assembly	1
2.3	A-22004	ROTOR ASSEMBLY	1
2.4	P-14005	8G x 3/8" L SELF TAPPING SCREW -PAN HEAD	4

ITEM NO.	PartNo	Description	QTY.
2.3.1	P-19001	ROTOR COVER	1
2.3.2	P-19002	ROTOR	1
2.3.3	P-22001	FEMALE BEARING HOLDER	1
2.3.4	P-14020	G10x0.75 X16MM LG7	7



ITEM NO.	PartNo	Description	QTY.
2.2.1	P-22051	Dirt Collector Shaft Support	1
2.2.2	P-22018	Collector Tube	1
2.2.3	P-22026	SHAFT	1
2.2.4	A-22024	Nozzle Assembly with Extensions - for FW350-FW400	6
2.2.5	P-14005	8G x 3/8" L SELF TAPPING SCREW -PAN HEAD	2
2.2.6	P-22050	Dirt Collector Shaft Retainer	1
2.2.7	P-14071	M5 x 3/8" Length - Button Head Socket Screw	4

ITEM NO.	PartNo	Description	QTY.
2.2.4.1	A-19018	ROUND NOZZLE	1
2.2.4.2	P-22025	NOZZLE EXTENSION	1
2.2.4.3	P-14101	Roller Spring Pipe	2

# ANNEXES

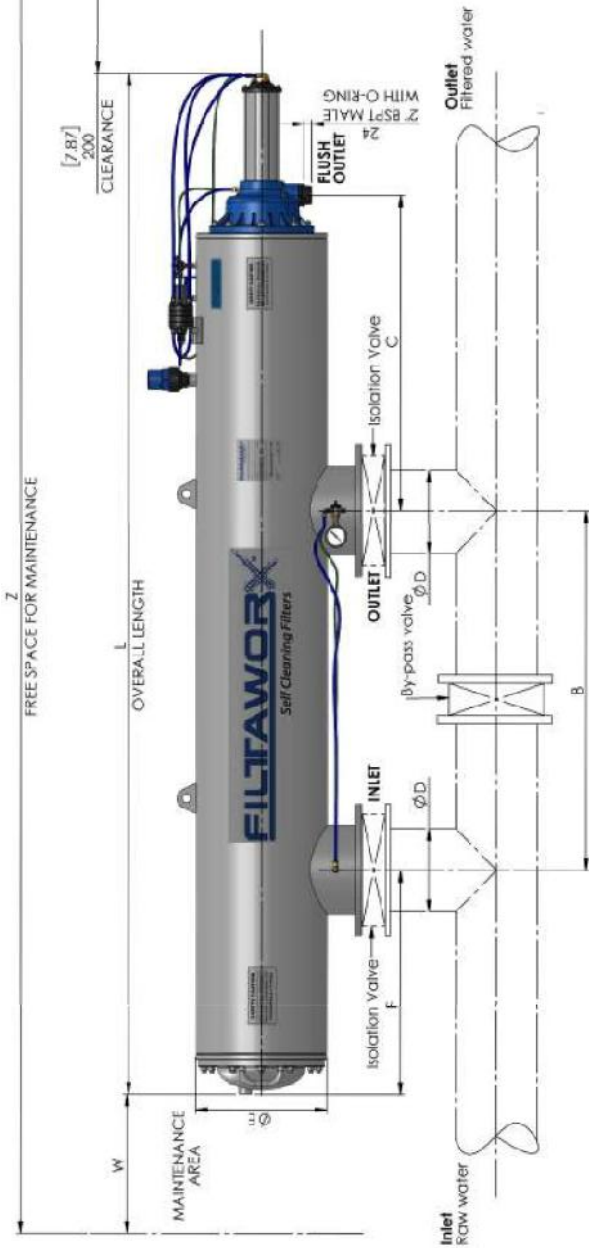
## ANNEX A Filter Data Sheets

25. Please see filter data sheets below:

Model No.	FW100EX	FW150	FW150EX	FW200	FW250	FW250EX	FW300	FW350	FW400	FW450
Inlet / Outlet (Nominal size mm/inch)	100/4"	150/6"	150/6"	200/8"	250/10"	250/10"	300/12"	350/14"	400/16"	450/18"
Connections	BS10 D/E Flanged / ANSI CL150 Flanged / DIN PN10 Flanged									
Min. operating pressure	200 kPa at all times (30psi / 2bar)									
Max. operating pressure	1000 kPa standard (150 psi / 10 bar)									
Filter Area (cm <sup>2</sup> /inch <sup>2</sup> )	5600 cm <sup>2</sup> / 868 inch <sup>2</sup>	8114 cm <sup>2</sup> / 1258 inch <sup>2</sup>		10420 cm <sup>2</sup> / 1615 inch <sup>2</sup>		12170 cm <sup>2</sup> /1886 inch <sup>2</sup>		15950cm <sup>2</sup> /2472 inch <sup>2</sup>		
Max. working temp	150 °F / 65 °C									
<b>Flushing Data</b>										
Drain line size mm/inch	50 / 2"									
Flush cycle duration	15-17 seconds (depending on pressure)									
Flush cycle volume	150 litres approx (depending on pressure)									
Min. flow for backwash	40 m <sup>3</sup> /hr @ 200 kPa (175 gpm @ 30 psi)									
<b>Materials of Construction</b>										
Filter body	304 grade stainless steel (optional 316 and 904L)									
Cover lid assy.	GRN (glass reinforced nylon), St/St									
Cleaning mechanism assy.	St/St, brass, GRN									
Fine screen	316 St/St mesh, GRN									
Coarse screen	304 Grade Stainless Steel (Optional 316 and 904L)									
Seals	NBR, EPDM									
Controller	St/St, Acetal, PVC									
Control tubing	Nylon									
<b>Weight kg (lbs)</b>										
Empty	85 (190)	105 (231)	115 (255)	130 (285)	155 (340)	235 (518)	240 (530)	285 (630)	345 (760)	420 (925)
Full	165 (365)	215(475)	265 (585)	320 (705)	345 (760)	540(1190)	550 (1212)	595 (1310)	742(1635)	800(1765)

# ANNEX B Filter Dimensional Data

Model No.	Nominal Size D												Dimensions (mm)												
	A		B		C		E		F		H		L		X		Y		Z		W				
	Inch	mm	Inch	mm	Inch	mm	Inch	mm	Inch	mm	Inch	mm	Inch	mm	Inch	mm	Inch	mm	Inch	mm	Inch	mm			
FW 100 EX	4	100	9.3	235	35.4	466	18.3	273	10.7	255.0	10.0	255.0	10.0	255.0	20.7	2059	81.1	725	28.5	360	14.2	3759	148.0	1500	59.1
FW 150	6	150	270	270	10.6	900	35.4	481	18.9	325	12.8	275.0	10.8	584	23.0	2124	83.6	784	30.9	360	14.2	3824	150.6	1500	59.1
FW 150 EX	6	150	270	270	10.6	900	35.4	884	34.8	325	12.8	275.0	10.8	584	23.0	2487	97.9	784	30.9	360	14.2	4187	164.8	1500	59.1
FW 200	8	200	270	270	10.6	900	35.4	966	38.0	325	12.8	385.0	15.2	587	23.1	2719	107.0	783	30.8	380	15.0	4769	187.8	1850	72.8
FW 250	10	250	302	302	11.9	900	35.4	966	38.0	325	12.8	385.0	15.2	631	24.8	2719	107.0	900	35.4	400	15.7	4769	187.8	1850	72.8
FW 250 EX	10	250	310	310	12.2	1100	43.3	966	38.0	406	16.0	687.0	27.0	664	26.1	3221	126.8	1048	41.3	450	17.7	5422	213.5	1850	72.8
FW 300	12	300	310	310	12.2	1100	43.3	966	38.0	406	16.0	687.0	27.0	664	26.1	3221	126.8	1048	41.3	450	17.7	5422	213.5	1850	72.8
FW 350	14	350	324	324	12.8	1270	50.0	966	38.0	406	16.0	531.0	20.9	673	26.5	3235	127.4	1062	41.8	450	17.7	5425	213.6	2000	78.7
FW 400	16	400	346	346	13.6	1270	50.0	966	38.0	457	18.0	531.0	20.9	723	28.5	3235	127.4	1084	42.7	450	17.7	5435	214.0	2000	78.7
FW 450	18	450	462	462	18.2	1270	50.0	966	38.0	559	22.0	551.0	21.7	893	35.2	3256	128.2	1200	47.2	450	17.7	5456	214.8	2000	78.7



## Warranty

The manufacturer warrants the product only against defects in material and workmanship for (2) years from date of dispatch. This limited warranty is valid only when the product is used in accordance with the manufacturer's standards and instructions and on condition that the customer fulfils his/her obligations set forth in this manual. The manufacturer's liability is limited to the replacement of defective parts with new or rebuilt parts, free of charge.

This warranty is extended only to the original purchaser. A purchase receipt or other proof of date of original purchase is required before warranty performance is rendered.

This warranty only covers failures due to defects in materials or workmanship, which occur during normal use. It does not cover damage caused by accidents, misuse, abuse, neglect, mishandling, misapplication, alteration, modification or service by anyone other than the manufacturer or any person/agent authorized by the manufacturer.

The manufacturer is not liable for incidental or consequential damages resulting from the use of this product or arising out of any breach of this warranty. All express and implied warranties, including the warranties of merchantability and fitness for a particular purpose, are limited to the applicable warranty period set forth above.

Faulty replaced parts are to be returned to Triangle Waterquip for inspection and assessment, so they in turn can claim warranty replacements from the manufacturer.

If you have any questions, contact your local dealer or our service department.



07 - 2022

# HELIX HYDRO

**T:** 03 9580 2122

**W:** [helixhydro.com.au](http://helixhydro.com.au)

**E:** [sales@helixhydro.com.au](mailto:sales@helixhydro.com.au)

**A:** 23 Sir Laurence Drive, Seaford, Vic 3198

VIC/TAS	P: 0427 033 967
WA/NT	P: 0409 115 895
NSW/ACT	P: 0414 675 663
QLD	P: 0417 733 508
SA	P: 0427 033 967



AUSTRALIAN  
OWNED AND  
OPERATED